



Owner's Manual

Drum & Tote Heating Cabinets

Electric Models

MODEL: _____

SERIAL NUMBER: _____

TABLE OF CONTENTS

WARRANTY	1
INTRODUCTION	2
SAFETY SYMBOL DEFINITIONS.....	3
CONTENT DEFINITIONS.....	4
SECTION 1 – GENERAL INFORMATION	4
1-1 PRODUCT DESCRIPTION.....	4
1-2 SAFETY.....	4
1-3 PPE (PERSONAL PROTECTIVE EQUIPMENT).....	6
1-4 RECEIVING & HANDLING.....	7
1-4.1 RIGGING.....	7
1-4.2 RECEIVING INSPECTION.....	7
SECTION 2 – INSTALLATION	8
2-1 LOCATION.....	8
2-2 LEVELING & ANCHORING.....	8
2-3 EXHAUSTING & VENTING.....	9
2-4 ELECTRICAL INSTALLATION.....	9
2-5 PRIOR TO START-UP.....	9
SECTION 3 – OPERATION & USE	10
3-1 GENERAL OPERATING PROCEDURES.....	10
3-2 EMERGENCY SHUT-DOWN.....	10
SECTION 4 – MAINTENANCE	11
4-1 GENERAL.....	11
4-2 MAINTENANCE ITEMS.....	11
4-3 HEATERS.....	12
4-4 SERVICE & REPLACEMENT PARTS.....	12
SECTION 5 – TROUBLESHOOTING	13
SECTION 6 – APPENDIX	15

LEWCO, Inc.

Warranty

Drum & Tote Heating Products

1. Unless separately agreed to otherwise, Warranty is for three (3) years, free from defects of faulty material or workmanship, effective from Buyer's receipt of goods and services.
2. Warranty does not include maintenance items (door gaskets, fan belts, thermocouples, etc.).
3. LEWCO, Inc. will replace or repair equipment proving defective in material or workmanship. Defective parts need to be shipped back to LEWCO, Inc. for inspection, at Buyers cost.
4. Failure due to abuse, overloading, maintenance neglect, exposure to corrosive or abrasive materials, operation under any degree of dampness, or improper use shall not be subject to this warranty.
5. Any modification to equipment or systems without LEWCO, Inc.'s written consent voids this warranty.
6. Standard warranty does not include labor to remove and/or install defective equipment.
7. If LEWCO, Inc.'s service is required for assistance on a warranty claim, labor will be charged at prevailing rate plus travel expenses.
8. LEWCO, Inc. shall not be liable for loss of profits, delays or expenses incurred by failure of said parts, whether incidental or consequential.
9. LEWCO, Inc. shall not be liable for failure of the goods to comply with federal, state or local laws.
10. LEWCO, Inc.'s warranty becomes null and void if payment in full is not received for goods and services.
11. See LEWCO, Inc.'s **GENERAL TERMS AND CONDITIONS** for additional warranty detail.



INTRODUCTION

Thank you for choosing LEWCO, Inc. for your process heating needs. This manual has been prepared by LEWCO engineers for use in familiarizing personnel with the design, installation, operation and maintenance of your LEWCO Drum & Tote Heating Cabinet. Information presented herein should be given careful consideration to assure safe, optimum performance of the equipment. This manual should always be accessible to the operators for quick reference.

This heating cabinet has been designed and manufactured in accordance with applicable National Codes and Standards in effect as of the date of manufacture. It is the responsibility of the end user to update equipment as necessary to comply with future code changes or revisions.

This manual should be used in conjunction with the drawing(s), data sheets, and component manufacturer's literature attached hereto that clarify specific features, installation, utility connections, operation, etc.

If you have any questions regarding this manual or the use of your LEWCO Heating Cabinet, please contact our Industrial Oven department by phone at (419) 502-2780 or by email at ovensales@lewcoinc.com.

NOTE: The information in this manual is subject to change without notice and does not represent an obligation on the part of LEWCO, Inc. LEWCO does not assume any responsibility for any errors that may appear in this manual and under no circumstances will LEWCO be held liable for technical or editorial omissions made herein, nor for direct, indirect, special, incidental, or consequential damages resulting from the use or defect of this manual.



NOTICE: No installation or operation of this equipment should take place until this manual has been studied and understood by the person(s) responsible.

Copyright © 2016 by LEWCO, Inc.

All rights reserved. Reproduction or copying of this manual by any means, electronic or mechanical, including photocopying, recording, or information storage and retrieval systems is not permitted without the written permission of LEWCO, Inc.

Manual Specific Safety Symbol Definitions	
	Safety Instruction where an electrical hazard is involved.
	Safety instruction where non-compliance would affect safety.
	Safety instruction where non-compliance could potentially cause an explosion.
	Safety instruction where non-compliance could potentially cause a fire.
	Safety instruction relating to safe operation of the equipment (ATTENTION).
	Safety instruction where non-compliance could potentially result in a pinch point or a description of a known existing pinch point.
	Safety instruction where non-compliance could potentially result in a pinch point or a description of a known existing pinch point.
	Indicates a hazardous situation which, if not avoided, will result in death or serious injury. The signal word "DANGER" is to be limited to the most extreme situations. DANGER [signs] should not be used for property damage hazards unless personal injury risk appropriate to these levels is also involved.
	Indicates a hazardous situation which, if not avoided, could result in death or serious injury. WARNING [signs] should not be used for property damage hazards unless personal injury risk appropriate to this level is also involved.
	Indicates a hazardous situation which, if not avoided, could result in minor or moderate injury. CAUTION [signs] without a safety alert symbol may be used to alert against unsafe practices that can result in property damage only.
	Is used to describe preferred to address practices not related to personal injury.
Equipment Specific Safety Definitions	
	DANGER: Hazardous voltage will cause severe injury or death. LOCK OUT POWER before servicing.
	WARNING: Potential arc flash hazard.
	CAUTION: Hot surface. Do not touch.

CONTENT DEFINITIONS:

Arc Flash: An arc flash is a phenomenon where a flashover of electric current leaves its intended path and travels through the air from one conductor to another, or to ground. The results are often violent and when a human is in close proximity to the arc flash, serious injury and even death can occur.

Circulating Fan: The fan used to “move” the air around the workspace in order to more evenly distribute and more efficiently transfer the heat from the heat source to the material.

SCR: Silicone Control Rectifier, used to control output to the heating elements.

Safety Device: An instrument, a control or other equipment that acts, or initiates action, to cause the unit to revert to a safe condition in the event of equipment failure or other hazardous event.

Temperature Controller: A device that measures the temperature and automatically controls the input of heat into the heating cabinet.

SECTION 1 – GENERAL INFORMATION

1-1 PRODUCT DESCRIPTION

The heating cabinet is an electrically heated system. Resistance electric heating elements are mounted on the workspace walls directly inside the unit. The casing is an insulated mild steel shell. Temperature is controlled by thermocouple actuated electronic temperature controllers.

Process heating applications involve a combination of time and temperature to achieve desired material properties. Although the process can sometimes be pre-determined based on heat transfer calculations and empirical data, these values are an engineering estimate at best. The precise combination of time and temperature, for a specific application, is best determined through actual trial use. By accurately monitoring time, temperature, and material properties closely, in a controlled environment, optimum process parameters can be safely and accurately determined.

1-2 SAFETY







WARNING: Only properly trained and qualified operators may use this equipment. Improper use may cause equipment damage, injury or death. Control systems are designed to react to system and operator input. Be sure to understand the system reaction before making any system adjustments.



Typically, a drum or tote heating cabinet is purchased for a specific application. If the application for this equipment has changed, or you have reason to doubt the adequacy of the equipment for the application, consult your LEWCO, Inc. representative for proper use.





All LEWCO Drum & Tote Heating Cabinets are equipped with an interior door release mechanism. This will allow anyone trapped inside the cabinet to escape, simply by unscrewing the handle shown in *Figure 1*. All personnel should be aware of this safety device.



Figure 1: Door Release

 DANGER	
	<ul style="list-style-type: none"> Materials with auto-ignition temperatures below the cabinet operating temperature should never be introduced into the cabinet. For some applications, such as those involving solvents, additional nonstandard safety features are required.
	<ul style="list-style-type: none"> Electric heating cabinets are NOT suitable for heating flammable or combustible materials. Explosion or fire may result from misapplication of this equipment. Electric heating cabinets are NOT suitable for installations in electrically classified hazardous areas.
	<ul style="list-style-type: none"> Disconnect and lockout electrical power and all other sources of energy before performing maintenance. Know where arc flash is possible and take proper precautions.
	<ul style="list-style-type: none"> Be sure any fan shafts have stopped rotating. Keep body, hands and foreign objects away from the inlet and outlet, and the other moving parts of the fan such as shafts, belts and pulleys.

 WARNING	
	<ul style="list-style-type: none"> Prior to placing drums or totes in the heating cabinet, loosen the bung fittings to relieve pressure that may build during heating.
	<ul style="list-style-type: none"> Standard heating cabinets are not suitable for operation above 300°F (150°C). Do not exceed this maximum temperature. Do not store contents or materials on top of, or directly against, the unit. Fire may result.

 CAUTION	
	<ul style="list-style-type: none"> Do not leave the unit in operation unattended. Property damage or injury to personnel may result. Maintain cleanliness inside and around the unit. Spill containment may be subjected to a build-up of flammable deposits, fluid, or combustible debris that may be fire hazards.
	<ul style="list-style-type: none"> Use caution when opening doors to avoid breathing air from inside the cabinet. Heated air can burn lungs. Do not breathe air from exhaust vent. This equipment is to be operated by trained personnel only. The heating cabinet's outer skin may be hot and burns could result. Use caution. When heating materials that generate hazardous vapors, venting or exhausting of the unit is required. This equipment may create a confined space hazard. The user is responsible for analyzing the installation in order to make a determination, posting warnings and complying with applicable OSHA standards pertaining to confined space hazards. Do not operate fans without belt & bearing guards in place as bodily injury may result. Always disconnect and lockout power before removing covers or guards.
	<ul style="list-style-type: none"> Pinch points may exist at door(s). Keep hands and arms clear. Vertical lift doors must be blocked before entering the workspace.

To reduce the possibility of injury to personnel operating, or in the vicinity of the heating cabinet, warning signs are posted at potential hazard points on the equipment. Examine the equipment and become familiar with potential hazard areas. Instruct all personnel to be aware of these areas and to heed all posted caution and warning signs.

Properly rated fire extinguishers should be located near the heating cabinet. Extinguishers should be inspected periodically in accordance with NFPA 10, "Standard for Portable Fire Extinguishers."

After complete installation of the equipment, a safety study should be made of the application and additional guards and warnings should be installed and posted as necessary. Any code requirements are the responsibility of the user and not that of LEWCO, Inc. Violation of the above safety rules hereby removes all product liability claims from LEWCO, Inc.



NOTICE: It is the responsibility of the owner to comply with all safety standards, including OSHA and other Federal, State, and Local codes or regulations.

1-3 PPE (PERSONAL PROTECTIVE EQUIPMENT)

PPE (Personal Protective Equipment) required will be site and process specific. LEWCO, Inc. recommends conducting a detailed study of your installation and process to determine what PPE will be required for safe operation.

Hearing Protection: According to OSHA protection against the effects of noise exposure shall be provided when the sound levels exceed those determined as unsafe.

Safety Glasses: It is never recommended to enter the workspace with the circulating fan(s) running. However, if anyone must do so for any reason, safety glasses **MUST** be worn.

Steel Toe Boots (Metatarsals): Nothing inherent to the heating cabinet or its process should require foot protection, aside from the loading and unloading of the unit. Use proper plant safety considerations for material handling and PPE.

Gloves/Sleeves: If unloading hot material always wear high temperature gloves. If the material being loaded/unloaded is sharp, protective gloves should be worn.

Temperature/Flame Resistant Clothing: If the material is being unloaded hot, wear the appropriate clothing. This may include temperature resistant sleeves, jacket, pants or any combination of the aforementioned clothing.

Fall Protection: Normal operation of the unit will not require the operator to be on top of the equipment, however, some maintenance and troubleshooting may require personnel to be more than 6' off of the ground. If this is the case, proper fall protection must be used at all times.

1- 4 RECEIVING & HANDLING

Special care must be taken in handling this equipment due to its configuration, size, and weight. Most LEWCO heating cabinets are equipped with either fork pockets or lifting lugs, also known as lifting eyes. Models not equipped with lifting lugs or fork pockets (typically low profile models), can be moved via fork truck. To do this, open the doors and place forks underneath the roof of the unit, then lift. It is recommended that wood blocks or another non-marring material be inserted between the forks and the inside roof of the unit to prevent scratches or dents.

1- 4.1 RIGGING

When applicable, lifting lugs are provided at the top (4) corners of the unit. It is important to note that rigging cables or chains must not exceed a maximum angle of 10 degrees from vertical (see *Figure 2*). Use a spreader beam, or rigging of adequate length, to avoid damage to the equipment. Please refer to any assembly drawings for specific assembly and rigging instructions.

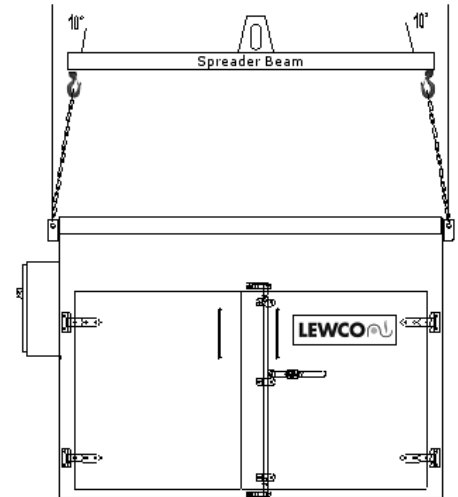

Figure 2: Typical Rigging

1- 4.2 RECEIVING INSPECTION

Before removing banding and/or packaging materials, locate the packing slip. The packing slip contains a complete list of all materials shipped. Verify completeness of shipment against packing slip for each item. Inspect each item for damage that could have occurred during shipment.

On collect shipments, all claims for shipping damage must be made against the carrier by the purchaser. All shipments received “short or damaged” must be noted on the freight bill when signed by the receiver. The delivering carrier may deny a claim if not noted on the freight bill when signed by the receiver. However, if damage is concealed, and not discovered at the time of delivery, an inspection must be requested to the delivering carrier within 24 hours.

All claims for shortages against the packing list must be made against LEWCO, Inc. within 48 hours of receipt. Claims for replacement materials and equipment submitted after 48 hours of receipt will be invoiced to the customer.

SECTION 2 – INSTALLATION

Prior to installation, the owner should consult their insurance underwriters for recommendations and requirements regarding the installation and maintenance of drum & tote heating cabinets.

2-1 LOCATION

Standard drum & tote heating cabinets are designed for indoor use only, unless the outdoor service package option is specified on the purchase order.

NOTE: Installation in unheated areas or areas without climate control may result in non-uniform temperatures or the inability to attain desired temperature. Condensation may also occur, which could damage the unit.

Due to the inherent hazards of heat processing equipment, including the possibility of fire, property damage, and personal injury, selection of the heating cabinet’s location must be carefully planned. In planning the location, consideration should be given to the following:

PERSONNEL SAFETY:



CAUTION: Avoid installations near exits or main aisles to minimize the risk to personnel associated with fire, explosion, or asphyxiation.

FLOOR: The heating cabinet should always be placed on a non-combustible surface with adequate load capacity. Consideration must be given to the weight of the cabinet, weight of the materials being processed, and the weight of any carts or fixtures.

PROXIMITY:



DANGER: Do not locate the heating cabinet against walls. To protect adjacent structures and equipment from excessive temperatures, provide an air space of approximately 12” around the unit. If 12” cannot be achieved, LEWCO requires a minimum airspace of at least 4”. Ensure there is adequate distance for the door(s) to fully open. Consider maintenance access to controls, thermocouples, filters, and heaters. Consideration should also be given to the proximity of adjacent storage areas, particularly those that may include flammable liquids or gasses, or combustible materials as these vapors or materials may be drawn into the heating cabinet through circulating fan(s) or exhaust vent(s).

VENTILATION: The unit should be located so that air circulation around the equipment is not restricted. Do not block fresh air inlets or exhaust outlets. Particular consideration should also be given to all fans and motors. Avoid installations in basements or other areas with restricted fresh air.

2-2 LEVELING & ANCHORING

Set the heating cabinet on a level, non-combustible, surface. The unit should be leveled both side to side and front to back in reference to the inside grating or floor of the unit. If necessary, shim or grout the unit. Leveling is important to insure proper door alignment and swing. Anchor the cabinet with expansion anchors through the holes provided. Use anchors 1/8” smaller than the holes provided.

2-3 EXHAUSTING & VENTING

If the cabinet was purchased with a vent option, a number of acceptable connection methods are available to exhaust the unit. To avoid exposure to operating personnel, the owner must determine a suitable vent/exhaust method based on the toxicity, amount, and weight of vapor being generated. Consult local stack emission restrictions if the vapors being exhausted may affect air quality.

Connection to an existing plant fume removal system is the preferred vent connection method. The vent connection is 5" OD duct. A sheet metal slip-on, draw band connection is adequate. At installations where a plant exhaust system is unavailable, a "chimney" connection is also an acceptable method to remove lower concentrations of lighter vapors. An outdoor vertical section of duct, of adequate height to produce a chimney effect, has proven successful in many applications. A rain cap is required on outdoor stacks.

Use the blast gate provided to attain an optimum combination of vapor exhaust and unit temperature. This may be especially important when trying to attain relative operating temperatures.

2-4 ELECTRICAL INSTALLATION

Electrical connections should be made by a qualified electrician in accordance with NFPA 70, "National Electric Code." The installation must also meet the requirements of any applicable state and local codes.

All standard model heating cabinets are shipped factory wired complete. Connect power to the main disconnect switch using wire of adequate size to carry the full load current rating of this device. Secure all connections and ground the unit adequately. A grounding lug is provided in the main control panel.

After wiring is complete, make a final check of all electrical connections to confirm that none have vibrated loose in transit from LEWCO. Tight power connections will reduce component failure due to poor contact.

If a circulating fan(s) option was included, check the fan(s) for proper rotation direction. An arrow on the fans housing indicates proper direction of rotation. The installer should also verify that the fan drive components (belt and pulleys) have not become misaligned or loose during shipment. Excessive noise and/or vibration may be the result of loose or misaligned drive components. As standard, proper rotation produces an airflow pattern that draws air into the fan inlet at the bottom of the cabinet and discharges air back into the top of the cabinet.

2-5 PRIOR TO START-UP

Prior to releasing the heating cabinet to production, all safety systems **MUST** be inspected and tested for function and operation. To check operation of a safety circuit, force the input criteria into a failure state and verify the heating cabinet reacts correctly.

Example: High-Limit Temperature Controller – While the heating cabinet is operating, adjust the high-limit setting to a temperature lower than the current cabinet temperature. The heating circuit for the cabinet should be disabled immediately.

Once the safety systems have been checked and proper operation verified, document all component settings for the unit. These settings should be kept with your operating instructions for reference during maintenance and annual safety inspections.

SECTION 3 – OPERATION & USE

3-1 GENERAL OPERATING PROCEDURES

Operators must be adequately trained in start-up and shut-down procedures, as well as the heating cabinet's safety features. It is the owner's responsibility to ensure that operators are also familiar with the cabinet's intended application and aware of the design limitations of the equipment in order to avoid misapplication.

Operating instructions specific to this equipment are detailed in the **Appendix, section 6-1**.

NOTE: Minimum operating temperature for standard models is 125°F (52°C). Temperature control below this minimum may be erratic. Consult LEWCO for applications requiring operation below this minimum.

3-2 EMERGENCY SHUT-DOWN

Your LEWCO, Inc. heating cabinet has been engineered and built to the highest industry standards. Only in the unlikely event of equipment malfunction or emergency, should the following steps be performed:

1. Press the red "Emergency Stop" button. If access to the emergency stop button is limited, or the unit does not have an emergency stop button, turn off the electrical disconnect providing power to the unit.
2. Depending on the severity of the issue, evacuate or restrict access to the area until the issue has been resolved.
3. When it is deemed safe to resume operation, twist the red emergency stop button to release it. The button should "pop-up" indicating its disengagement. Then follow normal start-up procedures.

SECTION 4 - MAINTENANCE

4-1 GENERAL

Industry experience indicates that improper maintenance is another leading cause of equipment failure, often resulting in property damage or injury to personnel. To maximize service life and assure safe, optimum, performance of this equipment, the owner should develop and follow a preventative maintenance program.



WARNING: Do not attempt any maintenance on this equipment unless all sources of energy are disconnected and locked out. Before performing work on fan(s), special caution must also be taken to secure the wheel.

4-2 MAINTENANCE ITEMS

This list of maintenance items is a general overview of the minimum items that may need to be addressed on your LEWCO Drum or Tote Heating Cabinet. The actual list may vary depending on the specific equipment provided. The owner should make the final determination on maintenance intervals and tasks to be performed while considering the working environment. Please review the supplied component literature for further detail and potential additional maintenance items.

Maintenance Items	Frequency			
	Daily	Monthly	6 Months	Annual
Inspect the cabinet workspace, and if applicable, the circulating fan(s), ductwork, and vent/ exhaust stack for accumulation of foreign matter. Clean as necessary.	■			
Inspect cabinet door(s) for gasket wear and tear. Replace as needed.	■			
Inspect electrical connections and components for tightness and signs of wear.		■		
Inspect circulating fan(s). Tighten set-screws between bearings and shaft, and also wheel set-screws on all circulating fans.		■		
Check for belt tension and wear on belt driven fans. Replace belt as needed.		■		
Lubricate circulating fan(s) shaft bearings every 500 hours of operation. As standard, no special heat resistant grease is required.		■		
Motors should be lubricated at least every 5,500 hours of service.			■	
Confirm exhaust rate at the stack outlet with nameplate or drawing. Inspect exhaust stack for cleanliness and integrity.			■	
Test all safety devices for proper function.				■
Verify proper function of Limit Controller (High-Limit Temperature Controller).				■
Measure full load amperage on each heater leg and compare to the schematic.				■
Calibrate recording devices. Refer to component literature.				■
Validate all thermocouple(s) / RTD's. Replace as necessary.				■
Conduct operator training course or refresher course.				■

NOTE: Air streams containing particulate or chemicals can cause abrasion or corrosion of fan parts. When such wear is discovered, a decision must be made as to whether to rebalance or replace the wheel.

4-3 HEATERS

Complete heating system operation can be verified at any time by checking the full load current at the output of the heater contactor. For 3-phase models the amperage should be balanced and equal on each leg within 10%. An imbalanced heater load is an indication of a failed heating element. The following table specifies theoretical full load current for various heater loads. The actual amperage as measured by an ammeter may vary by + / - 10%.

	2 kW	4 kW	6 kW	12 kW	18 kW	24 kW	30 kW	36 kW	42 kW
110/1/60	18	n/a	n/a	n/a	n/a	n/a	n/a	n/a	n/a
208/1/60	8	15	22	44	65	n/a	n/a	n/a	n/a
208/3/60	n/a	n/a	13	25	38	50	63	75	88
240/1/60	9	17	25	50	75	100	125	150	175
240/3/60	n/a	n/a	15	29	44	58	72	87	101
380/1/50	6	11	16	32	48	64	79	95	110
380/3/50	n/a	n/a	10	19	28	37	46	55	64
480/1/60	5	9	13	25	38	50	63	75	175
480/3/60	n/a	n/a	8	15	22	29	36	44	51
575/1/60	4	7	11	21	32	42	53	63	74
575/3/60	n/a	n/a	6	12	18	24	30	36	42

Heating elements in standard models are located in sealed tubes mounted either on the walls or in the bottom of the unit. They are accessible by removing the sheet metal access cover(s) on the outside of the cabinet at the end of the heater tube. Refer to the drawings provided to identify access to heating elements in non-standard locations.

4-4 SERVICE & REPLACEMENT PARTS

For service or replacements parts, please contact LEWCO's Customer Service Department by calling 419-625-4014, ext. 4012 or emailing customerservice@lewcoinc.com. Please be prepared to provide both your MODEL and SERIAL NUMBER when ordering. A list of replacement parts may be found in the Appendix, section 6-3.

SECTION 5 – TROUBLESHOOTING

PROBLEM	CAUSE(S)	SOLUTION
Control panel does not have power	No power supplied to the control panel	Verify main disconnect switch is on
	Blown fuse(s)	Verify continuity of the fuses before and after the main transformer
	Emergency Stop button is engaged	Verify the initial reason for the Emergency stop. If reason has been corrected, release the Emergency Stop.
Hot Box will not heat, heats slow, or will not reach set temperature	Power loss	Check incoming power to control panel from source. If line voltage is not present, check and make necessary corrections at source.
		Check voltage on load side of fuses and replace if needed.
		Check voltage on load side of heater relay/contactors or SCR while controller is calling for heat. If full voltage is present on all phases, check heaters for open circuit.
	Control power loss	Check input to heater relay/contactors or SCR. When temperature controller calls for heat, contactor or relay coils should have 120V control voltage across the coil. SCR's should have 4~20mA. Refer to schematic.
		Replace heater relay/contactors or SCR if above-cited control power is available and line side voltages appear while load side voltages do not appear.
	Thermocouple burned out	Replace thermocouple
	Open heaters	Check heater resistances with ohm meter and replace open heaters.
	Blown fuses	Check all heater fuses. Replace as necessary.
	Open phase	Check three-phase power at load end of heater relay/contactors or SCR.
	Failed or damaged heater elements	Replace heater elements
	Circulating fan(s) rotating in wrong direction	Verify fan rotation against fan direction label. If fan is rotating in the wrong direction, there is an incorrect phase sequence. To correct, reverse any two leads anywhere from source to fan motor.
	Temperature Controller	Check temperature controller for error messages and adjustments. Refer to temperature controller manual.
		If known, set P, I, D, constants on Temperature Controller. If unknown, initiate auto tune sequence. Refer to temperature controller manual for auto tune instructions.
Check output of temperature controller to see if it cycles. If output power is continuously present when controller does not call for power, replace temperature controller.		
Door switch	If door is not securely closed, door switch will disable heat - close door. If door is closed, inspect door switch for proper function. Replace if necessary.	

PROBLEM	CAUSE(S)	SOLUTION
Hot Box exceeds desired temperature (overheats)	Temperature Controller	Check temperature controller for error messages and adjustments. Refer to temperature controller manual.
		If known, set P, I, D, constants on Temperature Controller. If unknown, initiate auto tune sequence. Refer to temperature controller manual for auto tune instructions.
	Heater control failure	Check output of temperature controller to see if it cycles. If output power is continuously present when controller does not call for power, replace temperature controller.
Limit Controller High-Temp. Alarm will not turn off	High-Temp. condition exists	Wait for temperature to go below high-temp. set-point
	Limit Controller	Reset Limit Controller. If temperature is below set-point and alarm will not turn off when manually reset, replace Limit Controller.
	Hysteresis value	Hysteresis value is factory set at 20. Temperature must go 20°F. below Limit Controller set-point, before high-limit alarm can be rest. Verify Hysteresis value hasn't been changed.
	Limit Controller set wrong	Verify parameters and correct as necessary.
	Thermocouple	Inspect thermocouple. Replace if necessary
Circulating fan will not start	Motor failure or control power loss	Check fuses. Replace if needed.
		Check load side voltages on overload relay with fan control on. If three-phase imbalance voltage appears, service fan motor.
	Faulty Circulating Fan Start Switch	Check 120V power across starter coil A1 - A2 with fan control on. If power appears and starter does not energize, replace starter. Inspect wiring to switch. Verify all connections are secure. Tighten as necessary. If all wiring is secure, replace switch.
Circulating fan running slow & sluggish	Phase missing	Check fuses. Replace if needed.
		Check for balanced three-phase power from source and correct as necessary.
Excessive fan noise or vibration	Loose mounting bolts, setscrews, bearings or couplings.	Tighten hardware to the proper torque
	Fan shaft bearings	Lubricate or replace
	Fan motor	Lubricate motor
	Misaligned or excessive wear of couplings, bearings or misaligned or unbalanced motor.	Replace couplings and bearings, and realign balanced shaft and wheel.
	Accumulation of foreign matter on the wheel or wear/erosion of the wheel.	Clean or replace fan wheel depending on extent of damage

SECTION 6 – APPENDIX

The Appendix of this manual contains installation and operation specific information. If your installation requires non-standard information requirements, such as calibration certifications or equipment specific data, it will be found at the end of this section.

6-1 OPERATING INSTRUCTIONS

6-2 OPTIONAL EQUIPMENT

6-3 REPLACEMENT PARTS

6-4 GENERAL CONTROL INSTRUCTIONS

Also included with this manual:

- 1. DRAWINGS**
- 2. ELECTRICAL SCHEMATICS**
- 3. COMPONENT LITERATURE**

6-1 OPERATING INSTRUCTIONS

Standard heating cabinets are shipped from the factory with control parameters set-up for typical heating applications. The following operating procedures apply to all standard models. It is recommended that the owner post a copy of these instructions at the unit. Refer to the supplied component literature for further set-up and operation details.

NOTE: It is important to also read Appendix 6-2, Optional Equipment prior to initial start-up.



CAUTION: Do not leave this equipment in operation unattended.

START-UP

1. Turn the main power disconnect switch to the “ON” position. This will turn the heating elements on.
2. If the hot box is equipped with a circulating fan(s), push the “CIRCULATING FAN START” button(s). The green “CIRCULATING FAN START” button(s) should now be illuminated.
3. Using the Temperature Controller (also known as Process Controller) set the desired operating temperature. The controller will display two temperatures. The upper temperature indicates the current hot box temperature. The lower temperature indicates the set temperature. Refer to the applicable controls specific unit to your unit:
 - a. **Eurotherm 3216** Temperature Controllers (132 TC): To set the operating temperature; simply push the “Mode” up or down arrows to the desired temperature.
 - b. **Honeywell UDC1200** Temperature Controllers (132 TC): To set the operating temperature; push the “SETUP” button in the lower right corner. A green “SP” will appear in the lower display. Push the up or down arrow keys at the bottom of the controller to raise or lower the temperature set-point. When the desired temperature is set, push the “SETUP” key again to return to the normal display screen.

NOTICE: The Limit Controller has been factory set at 320°F (160°C) and should never be raised above this temperature or damage may occur. The high-limit set-point may be lowered at the owner’s discretion; however it should always exceed the Temperature Controller set-point by 20°F (11°C).

SHUT-DOWN

1. If hot box is operating above 200°F (93°C), it is important to allow it to cool down before turning off the circulating fan(s). To do this, set the temperature controller to 200°F. Once the hot box cools to 200°F., push the “CIRCULATING FAN STOP” button(s).
2. Turn the main power disconnect switch to the “OFF” position.

**** A general temperature controller instruction guide can be found in the Appendix, section 6-4.***

6-2 OPTIONAL EQUIPMENT

This is a general guide. Equipment listed below may or may not be applicable to your specific model. For more information and operating instructions on specific equipment, refer to the supplied component literature.

NOTE: Ensure all switches are turned off prior to turning the main disconnect switch off. Failure to do so may result in damage to controls.

CIRCULATING FAN: Circulating fan(s) should be left on throughout the entire heating cycle. Generally, it will improve heat-up time and produce more uniform heating by circulating heated air evenly around the product.

1. To turn the circulating fan(s) **on**, simply push the “CIRCULATING FAN START” button(s). The green “CIRCULATING FAN ON” button(s) should now be illuminated. To turn the circulating fan(s) **off**, push the red “CIRCULATING FAN STOP” button(s). The circulating fan(s) should now be off and the green “CIRCULATING FAN START” light(s) extinguished.

NOTE: High-temperature fans cool themselves while they are running. To avoid damage to the fan, allow the hot box to cool below 200°F (93°C) before terminating fan operation.

BATCH TIMER: The batch timer is infinitely adjustable up to 100 hours. It includes an illuminated ON/ OFF switch to indicate timed operation and sounds an audible alarm when time has elapsed.

1. For **Honeywell** or non-standard temperature controls:
 - To initiate the batch timer function, set the desired batch time interval and turn the timer selector switch to the “ON” position. Upon expiration of the batch time interval, an audible alarm will sound. To silence the audible alarm, turn the timer selector switch to the “OFF” position. Refer to batch timer literature for further details.
2. For **Eurotherm** temperature controls:
 - On the temperature controller, press the **SCROLL** button until “dWELL” is shown in the lower display and the current time is shown in the upper display. “Set Time Duration” will scroll across the bottom of the screen.
 - Press the **UP** and **DOWN** arrows to change the hours and minutes. The maximum time is 99 hrs. and 59 mins.
 - On the control panel, physically turn the **Timer selector switch** to the “ON” position.
 - When timer is running, “RUN” will be illuminated on the bottom of the controllers screen and “Timer Running” will scroll across the bottom of the screen.
 - When batch time is complete the alarm horn will sound, “Timer Running” will stop scrolling across the bottom of the screen, and “OP4” will be shown on the lower left corner of the display.
 - To turn off the alarm horn and reset the timer, turn the Timer selector switch to the “OFF” position.

NOTE: If the Timer selector switch is turned to the **OFF** in the middle of a batch time the timer will reset and start over when the switch is turned back **ON**. Batch time cannot be paused in the middle of a cycle.

CHART RECORDER: Single pen circular paper chart recorder allows for continuous monitoring of temperature data. Chart recorder comes with (1) Type “J” thermocouple input.

1. To turn the chart recorder on/ off, simply turn the “CHART RECORDER” switch to the “ON” or “OFF” position. The chart recorder should typically be turned on at the beginning of the batch.

DATA LOGGER: Multiple input digital data logger continuously records temperature and other process data. Data logger allows downloading of digital data files through USB or Ethernet connection. Data can also be viewed on a full color display or on a web server when connected to a network. *Note:* There are a couple different ways to retrieve the recorded data.

1. Setup the channels that need to be recorded. Recording is done automatically. The recorded data can then be retrieved in several different time intervals. The amount of data able to be recorded is limited only by memory present on the data logger. Once the memory fills up the data will begin overwriting the oldest data first. Connect computer or USB to data logger and archive at desired time frame.
2. Data can also be logged to a computer by permanently connecting the data logger to a network and continuously archiving the data.

DOOR SWITCH: The door switch is designed to terminate power to the heating elements when the door is opened. Normal operation, at previously set parameters, is initiated when the door is closed again. The door switch does not require any set-up. Please note that the door switch does not turn the circulating fan off.

DRUM ROTATORS: Drum rotators continuously agitate contents stored in 55-gallon drums.

1. Set the desired rotation speed(s) by using the “ROTATOR SPEED CONTROL” dial switch.
2. To turn the drum rotator(s) **on**, simply push the green “ROTATOR START” button. To turn the drum rotator(s) **off**, push the red “ROTATOR STOP” button.

RAMP/ SOAK CONTROLLER: Programmable ramp/ soak temperature controller with capability to store different recipes with multiple segments.

1. Enter or open the desired ramp/ soak program, then run it.

7-DAY TIMER: Programmable timer offers automatic start-up and shutdown times throughout the week (not intended for unsupervised operation). Illuminated On/Off switch allows both manual and automatic operation of unit.

1. Set the desired start-up and shut-down times for when you want the hot box run.
2. To turn the timer on/ off, simply turn the “AUTO TIMER” switch to the “ON” or “OFF” position.

6-3 REPLACEMENT PARTS

We apologize for any inconveniences you are having with your equipment. Below is a minimum list of common parts that may need to be replaced on your LEWCO Hot Box. If the part you need is not listed, please contact our customer service department and we'd be happy to help. Please be prepared to provide both your MODEL AND SERIAL NUMBER when ordering.

Phone: 419-625-4014, ext. 4012

Email: customerservice@lewcoinc.com

Part Description	Applicable Models:	Part #
Heating Element, 2 KW, 48" Hairpin, ___ Volts	ALL *except EC01S & EC01L	PCP0109- ___ (volts)
Heating Element, 1 KW, 27.5" Hairpin, ___ Volts	EC01S & EC01L	PCP0114- ___ (volts)
Door Gasket, Silicone Rubber	ALL	PCP0124
Process Controller (132 TC) - Eurotherm 3216, Relay Output	ALL	PCP2339-R
Limit Controller (135 LC) - Eurotherm 3216i	ALL	PCP2338
Process Controller (132 TC) - Honeywell UDC1200, Relay Output	ALL	PCP0796
Limit Controller (135 LC) - Honeywell UDC120L	ALL	PCP0798
Thermocouple, 8" Long	ALL	PCP0735-8
Mercury Relay, 3-Pole, 30 AMP	ALL *except EC24V, EC32V, EC6TV, EC8TV	PCP1305-30
Mercury Relay, 3-Pole, 60 AMP	ALL *except EC01S & EC01L	PCP1305-60
___ AMP Fuse, Class CC, 500 VAC	ALL	PCP1914- ___ (amps)
___ AMP Fuse, Class M, 250 VAC	ALL	PCP1297- ___ (amps)
___ AMP Fuse, Class CC, 600 VAC	ALL	PCP1296- ___ (amps)
___ AMP Fuse, Class J, 600 VAC	ALL	PCP1304- ___ (amps)
30 AMP Fuse block, Class CC	ALL	PCP8730-C-30
30 AMP Fuse block, Class J	ALL	PCP8730-J-30
60 AMP Fuse block, Class J	ALL	PCP8730-J-60
30 AMP Fuse block, Class M	ALL	PCP8730-M-30
Non-Reversing Contactor, 3-POLE, ___ AMP	ALL	PCP1335- ___ (amps)
Transformer, 100VA, 240-480/3/60 ("i" indicates international series: 208, 380-575/3/50 or 60 Hertz)	ALL	PCP1298-100(i)
Seven Day Timer, 120 VAC	ALL	PCP1675
Panel Mounted Horn, 85dB	ALL	PCP1695
Chart Recorder, Single Pen, Non-indicating	ALL	PCP6891
Solid State Overload Relay, ___ AMP	ALL	PCP1337- ___ (amps)

** Indicates an exception*

6-4 GENERAL CONTROL INSTRUCTIONS

This document is a general guide to assist LEWCO customers in becoming familiar with their temperature controls. It does not replace respective user's manuals. Anyone using any of the products mentioned herein is responsible for obtaining and understanding the user's manual before using any of these controllers. The user is responsible for setting up and configuring these devices to meet their own application requirements, not limited to but including adjusting set points, and setting up alarms. Refer to the applicable Eurotherm (6-4.1) or Honeywell (6-4.2) control instructions per your specific model.

6-4.1 EUROTHERM CONTROL INSTRUCTIONS

Eurotherm Tech Support: (800) 849-5655

GC Controls Tech Support: (440) 779- 4777

BUTTON LEGEND:

Page key	
Scroll key	



TO CHANGE THERMOCOUPLE TYPE:

- ❑ Press and hold the **PAGE** button until **LEv3** shows in the upper display and **GOTO** shows in the lower display. Release the **PAGE** button.
- ❑ The word **CODE** will be shown in the lower display and a **"0"** will be shown in the upper display
- ❑ Press the **UP** and **DOWN** arrows and change the **"0"** to a **"3"**
- ❑ Press the **PAGE** button until **INPUT** is shown in the lower display.
- ❑ Press the **SCROLL** button until **IN.TYP** is shown in the lower display and the current type is shown in the upper display (**J.TC**)
- ❑ Press the **UP** and **DOWN** arrows and change to desired units type
- ❑ Press the **SCROLL** button to save
- ❑ Press and hold the **PAGE** button again and until **CONF** is in the upper display and **GOTO** is in the lower display
- ❑ Press the **UP** and **DOWN** arrows and change **LEv3** to **LEv1**
- ❑ Controller will cycle power and automatically restart.

TO CHANGE ENGINEERING UNITS (°F TO °C):

- ❑ Press and hold the **PAGE** button until **LEv1** shows in the upper display and **GOTO** shows in the lower display. Select access level will scroll through the lower display.
- ❑ Press the **UP** and **DOWN** arrows and change **LEv1** to **LEv2**
- ❑ The word **CODE** will be shown in the lower display and a **"0"** will be shown in the upper display
- ❑ Press the **UP** and **DOWN** arrows and change the **"0"** to a **"2"**
- ❑ Press the **SCROLL** button until **UNITS** is shown in the lower display and the current units are shown in the upper display
- ❑ Press the **UP** and **DOWN** arrows and change to desired units °F

INSTRUCTIONS - Temperature Controller: 3216

Description: The 3216 Process Controller is a 1/16-DIN highly precise temperature controller. **Purpose:** Provide precise temperature control

TO CHANGE SET-POINT: Press the **UP** and **DOWN** arrows until desired set-point is reached

TO VIEW THE WORKING OUTPUT:

- ❑ Press the **SCROLL** (2nd from the left) button
- ❑ Press the **UP** and **DOWN** arrows, value will show between **0-100%**

NOTE: If heat output is on **OP1** or **OP2** will show in the upper left hand corner of the controller

TO AUTOTUNE THE CONTROLLER:

- ❑ Press and hold the **PAGE** (1st on the left) button until **LEv1** shows in the upper display and **GOTO** shows in the lower display. Select access level will scroll through the lower display.
- ❑ Press the **UP** and **DOWN** arrows and change **LEv1** to **LEv2**
- ❑ The word **CODE** will be shown in the lower display and a **“0”** will be shown in the upper display
- ❑ Press the **UP** and **DOWN** arrows and change the **“0”** to a **“2”**
- ❑ Press the **SCROLL** button until **A.TUNE** is shown in the lower display and **OFF** is shown in the upper display
- ❑ Press the **UP** and **DOWN** arrows and change the **OFF** to **ON**

NOTE: When Autotune is running **TUNE** will flash in the upper display. When this stops flashing the Autotune is complete.

INSTRUCTIONS - Limit Controller: 3216i

Description: The 3216i is a 1/16-DIN FM approved alarm indicator with one FM Approved form C relay output. Terminals AA, AB, and AC are dedicated to this Alarm. **Purpose:** If an alarm set-point is exceeded or a sensor failure occurs, the alarm relay will change state. Once the sensor fault and PV return to a safe state and have been acknowledged the relay will return to their original state.

TO ACKNOWLEDGE / RESET THE ALARM RELAY:

- ❑ The alarm relay is FM approved and must be manually acknowledged. Once the process variable has returned to a safe value and the alarm is acknowledged the relays will automatically reset. The alarm can be acknowledged by pressing the **PAGE** and **SCROLL** buttons at the same time.

TO CHANGE ALARM SET POINTS:

- ❑ Press the **SCROLL** button. The display will show the current set point in the upper display and **A1.HI** in the lower display
- ❑ Press the **UP** and **DOWN** arrows until desired set point is reached
- ❑ Press the **PAGE** button to exit

NOTE: Limit Controller set-point should be 20°F. above maximum operating temperature.

TO ADJUST THE ALARM HYSTERESIS VALUE:

Hysteresis is the difference between the point at which the alarm switches **ON** and the point at which it switches **OFF**. It is used to prevent relay chatter.

- ❑ Press the **SCROLL** until **A1.HYS** is shown in the lower display the current hysteresis value is shown in the upper display.
- ❑ To adjust the hysteresis value, use the **UP** or **DOWN** button; the minimum value is 1.

LEWCO PARAMETERS FOR EUROTHERM 3216 WITH RELAY OUTPUT			
INPUT			
Name	Description	Value	Value Description
IN.TYP	Input Type	J Tc	J Thermocouple
UNITS	Display Units	°F	Degrees Fahrenheit
DEC.P	Decimal Points	nnnn	
RNG.HI	Range High Limit	300	
RNG.LO	Range Low Limit	0	
PV.OFS	PV Offset	0	
FILT.T	Filter Time	1.6	
CJC.TYP	CJC Type	Auto	Automatic Compensation
SB.TYP	Sensor Break Type	on	
CJC.IN	CJC Temperature	75.75	
PV.IN	Process Variable	75.61	
MV.IN	Millivolt Input Value	0	
RC.FT	ROC Filter Time	1.6	
RC.PV	PV Derivative	-0.46	
IO1			
Name	Description	Value	Value Description
1.ID	IO 1 Type	rELY	Relay Fitted
1.FUNC	IO 1 Function	HEAt	Heat Output
1.PLS	Output 1 Minimum Pulse Time	2	
OP2			
Name	Description	Value	Value Description
2.ID	Output 2 Type	dC.rt	DC Output
2.FUNC	Output 2 Function	none	Unconfigured
2.RNG	DC Output Range	4.20	
LA			
Name	Description	Value	Value Description
L.TYPE	Logic Input Type	none	Unconfigured
l.din	Logic Input Function	none	Unconfigured
l.sens	Logic Input Sense	nor	
LB			
Name	Description	Value	Value Description
L.TYPE	Logic Input Type	none	Unconfigured
l.din	Logic Input Function	nonE	Unconfigured
l.sens	Logic Input Sense	nor	
ct.inp			
Name	Description	Value	Value Description
CT.ID	Module Type	none	Unconfigured
ct.src	CT Source	nonE	Unconfigured
CT.rng	CT Range	10	
ct.lat	CT Alarm Latch Type	none	Unconfigured
ld.alm	Load Current Threshold	Off	
lk.alm	Leak Current Threshold	Off	
hc.alm	Overcurrent threshold	Off	
ld.amp	Load Current	24	
lk.amp	Lead Current	0	
ct.mtr	Current Meter Range	10	

SP			
Name	Description	Value	Value Description
SP.SEL	Setpoint Select	SP1	Setpoint 1
SP1	Setpoint 1	0	
SP2	Setpoint 2	0	
SP.HI	Setpoint High Limit	300	
SP.LO	Setpoint Low Limit	0	
REM.SP	Remote Setpoint	0	
L-R	Remote Setpoint Select	No	
SP.RAT	Setpoint rate Limit	OFF	
RampU	Setpoint Ramp Units	min	Minutes
LOC.T	Local Setpoint Trim	0	
REM.HI	Remote Input High Scalar	9999	
REM.LO	Remote Input Low Scalar	-1999	
ROP.HI	Setpoint Retrans. High	300	
ROP.LO	Setpoint Retrans. Low	0	
CTRL			
Name	Description	Value	Value Description
CTRL.H	Heating Type	Pid	Control Output Configured as PID
CTRL.C	Cooling Type	oFF	Unconfigured
CTRL.A	Control Action	rEv	Reverse Acting (Negative Feedback)
PB.UNT	Proportional Band Units	EnG	Engineering Units
A.TUNE	Auto-tune Enable/Disable	OFF	
PB	Proportional Band	30	
TI	Integral Time	360	
TD	Derivative Time	60	
CB.HI	Cutback High	Auto	
CB.LO	Cutback Low	Auto	
MR	Manual Reset	0	
LBT	Loop Break Time	OFF	
OP.HI	Output High	100	
OP.LO	Output Low	0	
Safe	Safe Output Power	0	
F.MOD	Forced Manual Output Mode	nonE	Track
F.OP	Forced Output	0	
A-M	Loop Mode	Auto	
LBR	Loop Break Status	No	
TU.HI	Tune High Limit	100	
TU.LO	Tune Low Limit	0	
ALARM			
Name	Description	Value	Value Description
A1.TYP	Alarm 1 Type	nonE	Unconfigured
TIMER			
Name	Description	Value	Value Description
TM.CFG	Timer Configuration	nonE	Unconfigured
COMMS			
Name	Description	Value	Value Description
ID	Comms Identity	nonE	Unconfigured

CAL			
Name	Description	Value	Value Description
PHASE	Calibration Phase	nonE	
VALUE	DC Output reading	-	
GO	Calibration Start	-	
ACCESS			
Name	Description	Value	Value Description
Goto	Select Access Level	-	
LEV2.P	Level 2 Passcode	2	
LEV3.P	Level 3 Passcode	3	
CONF.P	Config Passcode	4	
ID	Customer ID	0	
HOME	Home Display	Std	SP / Manual Power
K.LOCK	Keyboard Lock	nonE	
COLD	Cold Start Enable/Disable	No	
STBY.T	Standby Type	Abs.A	Hi & Lo Alarms Active on Standby
PASS.C	Feature Passcode	3237	
PASS.2	Feature Passcode 2	3455	

6-4.2 HONEYWELL CONTROL INSTRUCTIONS

Honeywell Tech Support: (800-423-9883)

“Honeywell,” “UDC1200,” “UDC1700,” “DC120L” and “DR4300,” as well as certain other terms and phrases are trademarks of Honeywell. Honeywell terminology is used in this document for instructional use only. LEWCO, Inc. is not affiliated with Honeywell.

UDC1200 & 1700 PROCESS CONTROLLERS:

Adjust the Process Controller Set point (SP):

- ❑ From the Operator Display, indicated by the “Process Variable” (PV) or *actual workspace temperature* shown in the upper display and the Set point (SP) shown in the lower display, do the following:
- ❑ Press the “**SETUP**” key once.
- ❑ “**SP**” should appear in the lower display and the current Set point value should show in the upper display.
- ❑ Press the appropriate “**ARROW**” key to raise or lower the Set point to the desired value.
- ❑ Press the “**SETUP**” key to exit or leave it and it will exit automatically within a minute.



Accessing the Settable Parameters in the Controller:

- ❑ Press the **“SETUP”** key and **“UP ARROW”** key simultaneously.
TIP: Use your *thumbs*. It can be difficult and frustrating attempting to press both exactly simultaneously with two fingers on the same hand since they are different lengths.
- ❑ **“OPtr”** should appear in the upper display and **“SLCt”** should show in the lower display.
- ❑ Press the **“UP ARROW”** key to scroll through the available menu selections (upper display), which will be **“SEtP,”** (setup*) **“ConF,”** (configure*) **“inFo,”** (information) **“Atun”** (auto-tune) and back to **“OPtr,”** (operator) in that order as you continue to press the **“UP”** ARROW key.
- ❑ Press the **“SETUP”** key to access any of the above selections to enter that menu.
- ❑ For pass code protected, menus, follow instructions below.
- ❑ Press the **“SETUP”** key and **“UP ARROW”** key simultaneously to get out of that menu and back to the selection menu.
- ❑ To get out of the selection menu, scroll to **“OPtr”** and press the **“SETUP”** key and you should again see the “Process Variable” (PV) is shown in the upper display and the Set point (SP) is shown in the lower display.

NOTE: Figures 1 and 2 on the following pages list Settable Parameters, their original Honeywell factory defaults and LEWCO factory settings for SETUP (SEtP) and CONFIGURE (ConF) Menus. Not all parameters shown in the tables will be displayed on a given controller based on whether or not associated options have been installed.

Accessing Pass Code Protected Settable Parameters: (reference “Accessing the Settable Parameters in the Controller,” above)

- ❑ The SETUP (**SEtP**) and CONFIGURE (**ConF**) menus require the entry of a pass code to enter. Default pass codes are listed in the tables below.
- ❑ Once you have pressed the **“SETUP”** key to access either of the above menus, **“ULoc”** will appear in the lower display and **“0”** will appear in the upper display.
- ❑ At this prompt, press the **“UP ARROW”** key until the appropriate pass code appears (i.e. **“10”**, **“20,”** etc.).
- ❑ Press the **“SETUP”** key to enter.
- ❑ If the entered pass code was correct, a new display will show the first parameter available under that menu. If the entered pass code was incorrect, the display will return to the *menu* display.
TIP: If you feel that the pass code that you entered was correct, but you are returned to the menu display, try entering either **“1”** or the pass code you thought it should have been plus one (i.e. you thought it should have been **“10”** but **“10”** did not work, try **“1”** or **“11.”** The reason for this is that when setting the pass code and exiting the menu, it is easy to increment the pass code by **“one.”**

Finding the Pass Codes: (If you cannot remember what they are)

- ❑ Power down the controller. Wait ten seconds after the display goes blank and power back up.
- ❑ Once the controller is powered up, and before the display lights up, press **AND HOLD** the **“SETUP”** key and **“UP”** ARROW keys simultaneously.
- ❑ While holding the **“SETUP”** key and **“UP”** ARROW keys all functional LED segments in the display will light up and display what appears to be all **“eights”** with decimals between all of them.
- ❑ Continue to **HOLD** the **“SETUP”** key and **“UP”** ARROW keys simultaneously.
- ❑ After about ten seconds, the display will change to indicate the **“ConF”** in the lower display and its pass code in the upper display. At this time you may release the keys and scroll through the other pass codes.

Enter the **SETUP** Menu and Adjust Parameters Listed in Table 1:

- ❑ Press the “**UP ARROW**” key and the “**SETUP**” key simultaneously.
- ❑ Press the “**UP ARROW**” key until “**SEtP**” appears on the display.
- ❑ Press the “**SETUP**” key once to accept.
- ❑ “**ULoc**” should appear on the display.
- ❑ Press the “**UP ARROW**” key until “**10**” (default pass code) appears on the upper display.
- ❑ Press the “**SETUP**” key once to accept.
- ❑ “**Filt**” should appear on the lower display.
- ❑ At this point you may scroll through the parameters using the “**SETUP**” key.
- ❑ Once you have reached the parameter you wish to change, press the “**UP ARROW**” or “**DOWN ARROW**” to change the value.
- ❑ Press the “**SETUP**” key to scroll to the next parameter or repeatedly until “**SLoc**” appears in the lower display, indicating that you have reached the end of the settable parameters under that menu.
- ❑ Press the “**UP ARROW**” key and the “**SETUP**” key simultaneously to exit the “**SETUP**” menu and return to the menu selection display.

Enter the **CONFIGURE** Menu and Adjust Parameters Listed in Table 2:

- ❑ Press the “**UP ARROW**” key and the “**SETUP**” key simultaneously.
- ❑ Press the “**UP ARROW**” key until “**ConF**” appears on the display.
- ❑ Press the “**SETUP**” key once to accept.
- ❑ “**ULoc**” should appear on the display.
- ❑ Press the “**UP ARROW**” key until “**20**” (default pass code) appears on the upper display.
- ❑ Press the “**SETUP**” key once to accept.
- ❑ “**InPt**” should appear on the lower display.
- ❑ At this point you may scroll through the parameters using the “**SETUP**” key.
- ❑ Once you have reached the parameter you wish to change, press the “**UP ARROW**” or “**DOWN ARROW**” to change the value.
- ❑ After a parameter value has been changed, the displayed value (upper display) will *BLINK*.
- ❑ Press the “**Man/Auto**” key once to accept.
- ❑ Press the “**SETUP**” key to scroll to the next parameter or repeatedly until “**CLoc**” appears in the lower display, indicating that you have reached the end of the settable parameters under that menu.
- ❑ Press the “**UP ARROW**” key and the “**SETUP**” key simultaneously to exit the “**CONFIGURE**” menu and return to the menu selection display.

Figure 1:

PROCESS CONTROLLER (UDC1200) SETUP RECORD			
Controller Serial Number:			
Parameter	Lower Display	Factory Default	LEWCO Settings
Input Filter Time Constant	Filt	2	2
Process Variable Offset	OFFS	0	0
Primary (Heat) Power	PPbJ	-	
Secondary (Cool) Power	SPbJ	-	
Primary Proportional Band	Pb P	10	10
Secondary Proportional Band	Pb S	10	10
Automatic Reset (Integral Time)	ArSt	5	5
Rate (Derivative Time)	rAtE	1.15	1.15
Overlap/Deadband	OL	0	0
Manual Reset	biAS	25	25
Primary ON/OFF Differential	diFP	0.5	0.5
Secondary ON/OFF Differential	diFS	0.5	0.5
Prim. & Sec. ON/OFF Diff.	diFF	0.5	0.5
Set point Upper Limit	SPuL	Range Max	Max Design Temp
Set point Lower Limit	SPLL	Range Min	Range Min
Primary Output Power Limit	OPuL	100	100
Output 1 Cycle Time	Ct1	32	16 or 32
Output 2 Cycle Time	Ct2	32	diSA
Output 3 Cycle Time	Ct3	32	diSA
High Alarm 1 Value	PhA1	Range Max	Range Max
Low Alarm 1 Value	PIA1	Range Min	Range Min
Deviation Alarm 1 Value	dAL1	5	5
Band Alarm 1 Value	bAL1	5	5
Alarm 1 Hysteresis	AHY1	1	1
High Alarm 2 Value	PhA2	Range Max	Range Max
Low Alarm 2 Value	PLA2	Range Min	Range Min
Deviation Alarm 2 Value	dAL2	5	5
Band Alarm 2 Value	bAL2	5	5
Alarm 2 Hysteresis	AHY2	1	1
Loop Alarm Time	Lat1	99.59	99.59
Auto Pre-Tune	Apt	diSA	diSA
Auto/Manual Control Selection	PoEn	diSA	diSA
Set point Ramping	SPr	diSA	diSA
Set point Ramp Value	rP	-	-
SP Value	SP	Range Min	Range Min
SP1 Value	SP1	Range Min	Range Min
SP2 Value	SP2	Range Min	Range Min
Setup Lock Code	Sloc	10	10

Figure 2:

PROCESS CONTROLLER (UDC1200) CONFIGURATION RECORD			
Controller Serial Number:			
Parameter	Lower Display	Factory Default	LEWCO Settings
Input Range/Type	inPt	JF	JF
Scale Range Upper Limit	ruL	1401	1401
Scale Range Lower Limit	rLL	32	32
Decimal Point Position	dPos	1	1
Control Type	CtYP	SnGL	SnGL
Primary Output Control Action	Ctrl	rEv	rEv
Alarm 1 Type	ALA1	P_Hi	nonE
High Alarm 1 Value	PhA1	Range Max	
Low Alarm 1 Value	PLA1	Range Min	
Deviation Alarm 1 Value	dAL1	5	
Band Alarm 1 Value	bAL1	5	
Alarm 1 Hysteresis	AHY1	1	
Alarm 2 Type	ALA2	P_Lo	nonE
High Alarm 2 Value	PhA2	Range Max	
Low Alarm 2 Value	PLA2	Range Min	
Deviation Alarm 2 Value	dAL2	5	
Band Alarm 2 Value	bAL2	5	
Alarm 2 Hysteresis	AHY2	1	
Loop Alarm	LAEn	diSA	diSA
Loop Alarm Time			
Alarm Inhibit	Inhi	nonE	nonE
Output 1 Usage	USE1	Pri	Pri
Linear Output 1 Range	tYP1	0-10	
Retransmit Output 1 Scale Max.	ro1H	Range Max	
Retransmit Output 1 Scale Min.	ro1L	Range Min	
Output 2 Usage	USE2	A2_d	
Linear Output 2 Range	tYP2	0-10	
Retransmit Output 2 Scale Max.	ro2H	Range Max	
Retransmit Output 2 Scale Min.	ro2L	Range Min	
Output 3 Usage	USE3	0-10	
Linear Output 3 Range	tYP3	Range Max	
Retransmit Output 3 Scale Max.	ro3H	Range Min	
Retransmit Output 3 Scale Min.	ro3L	1	
Display Strategy	diSP	-	1
Comms Protocol	Prot	-	
Bit rate	bAud	-	
Comms Address	Addr	-	
Comms Write	CoEn	-	
Digital Input Usage	diGi	-	
Config Lock Code	Cloc	20	20

Change Display from Fahrenheit to Celsius:

Enter the Configuration Mode:

- Press the “UP ARROW” key and the “SETUP” key **simultaneously**.
- Press the “UP ARROW” key until “ConF” appears on the display.
- Press the “SETUP” key once to accept.
- “ULoc” should appear on the display.
- Press the “UP ARROW” key until “20” appears on the display.
- Press the “SETUP” key once to accept.
- “InPt” should appear on the display.
- Press either “ARROW” key until “JC” appears on the display.
- Press the “Man/Auto” key once to accept.
- Press the “SETUP” key once to move to the Range Upper Limit” parameter.
- “ruL” should appear on the display.
- Press either “ARROW” key until “761” appears on the display.
- Press the “Man/Auto” key once to accept.
- Press the “SETUP” key once to move to the Range Lower Limit” parameter.
- “rLL” should appear on the display.
- Press either “ARROW” key until “0” appears on the display.
- Press the “Man/Auto” key once to accept.
- Press the “UP ARROW” key and the “SETUP” key **simultaneously**.
- Press the “UP ARROW” key until “OPtr” appears on the display.
- Press the “SETUP” key once to accept.

Adjust the Process Controller Set point (SP):

- The upper display should now indicate the Process Variable in degrees C and the lower display should indicate a Set-Point of “0”
- Press the “SETUP” key once to enter the Set-Point entry mode.
- Press the “UP ARROW” key until the desired temperature in degrees C appears on the display.
- Press the “SETUP” key once to accept.
- The upper display should now indicate the Process Variable in degrees C and the lower display should indicate the Set-Point in degrees C.

Enter the ACCU-TUNE (Atun) Menu and Enable or Disable:

ACCU-TUNE consists of two different tuning functions; “Pre-Tune,” which generates the initial optimum values in the PID and “Self-Tune,” which can be used to refine the values in the PID as the controller is operated under “normal” conditions over time. Pre-Tune can only be engaged if the temperature is significantly less than the Set point and disengages automatically when done and is indicated by a blinking “AT” light on the controller. Self-Tune must be disengaged manually once one is comfortable that the controller is tuned for normal conditions and is indicated by a steady “AT” light on the controller.

- Press the “UP ARROW” key and the “SETUP” key simultaneously.
- Press the “UP ARROW” key until “Atun” appears on the upper display.
- Press the “SETUP” key once to enter the Accutune menu.
- “Ptun” should appear on the lower display.
 - If “ULoc” appears in the lower display instead then someone has set up a pass code.
 - At the “ULoc” prompt, press the “UP ARROW” key until the appropriate pass code appears (i.e. “10” or “20,” etc.). If you do not know the pass code, refer to the index.
 - Press the “SETUP” key once to accept.
 - “Ptun” should now appear on the lower display.
- At this point you may toggle between “ON” and “OFF” using the “UP ARROW” key.
 - If “ON” cannot be selected, it means that the PV is too close to the SP for “Pretune” (Ptun) to engage.
- Once Pre-Tune is accessed and engaged or disengaged, press the “SETUP” key once to accept and advance to Self-Tune, where “Stun” appears in the lower display.
- You may now toggle between “ON” and “OFF” using the “UP ARROW” key.
- Once Self-Tune is accessed and engaged or disengaged, press the “SETUP” key once to accept.
- “tLoc” should appear in the lower display.
- You may set a pass code using the “UP ARROW” or “DOWN ARROW”.

- ❑ Press the “UP ARROW” key and the “SETUP” key simultaneously to exit the “Atun” menu and return to the menu selection display.

UDC120L LIMIT CONTROLLER:

Adjust the Limit Controller Set point (SP):

- ❑ Press the “UP ARROW” key and the “SETUP” key **simultaneously**.
- ❑ “ULoc” should appear in the lower display and a zero should appear in the upper display.
- ❑ At this prompt, press the “UP ARROW” key until the appropriate pass code appears (i.e. “10” or “20,” etc.).
- ❑ Press the “SETUP” key.
- ❑ If the entered pass code was correct, a new display will show the first parameter available under that menu. If the entered pass code was *not* correct, the display will return to the *menu* display.

TIP: *If you feel that the pass code that you entered was correct but you are returned to the menu display, try entering either “1” or the pass code you thought it should have been plus one (i.e. you thought it should have been “10” but “10” did not work, try “1” or “11.” The reason for this is that when setting the pass code and exiting the menu, it is easy to increment the pass code by “one.”*

Once you make it past the pass code:

- ❑ “SP” should appear in the lower display and the current Set point value should show in the upper display. A small red “s” should appear in the right of the lower display indicating that the controller is in “set up” mode.
- ❑ Press the appropriate “ARROW” key to raise or lower the Set point to the desired value.
- ❑ Press the “SETUP” key until “Loc” appears in the lower display.
- ❑ Press the “UP ARROW” key and the “SETUP” key **simultaneously** to exit or leave it and it will exit automatically within a minute.

Finding the Pass Codes if you cannot remember what they are:

- ❑ Power down the controller. Wait ten seconds after the display goes blank and power back up.
- ❑ Once the controller is powered up, and before the display lights up, press **AND HOLD** the “SETUP” key and “UP” ARROW keys simultaneously.
- ❑ While holding the “SETUP” key and “UP” ARROW keys all functional LED segments in the display will light up and display what appears to be all “eights” with decimals between all of them.
- ❑ Continue to **HOLD** the “SETUP” key and “UP” ARROW keys simultaneously.
- ❑ After about ten seconds, the display will change to indicate the “ConF” in the lower display and its pass code in the upper display. At this time you may release the keys and scroll through the other pass codes.

NOTE: *Limit Controller set-point should be 20° F. above maximum operating temperature.*

LIMIT CONTROLLER (UDC120L) SETUP RECORD			
Controller Serial Number:			
Parameter	Lower Display	Factory Default	LEWCO Settings
Limit Set point Value	SP	Range Max.	Max Design+20F
Limit Hysteresis	HYS _t	1	
Input Filter Time Constant	Filt	2	2
Process High Alarm 1 Value	PhA1	Range Max	
Process Low Alarm 1 Value	PLA1	Range Min	
Deviation Alarm 1 Value	dAL1	5	5
Band Alarm 1 Value	bAL1	5	5
Alarm 1 Hysteresis	AHY1	1	1
High Alarm 2 Value	PhA2	Range Max	Range Max
Low Alarm 2 Value	PLA2	Range Min	Range Min
Deviation Alarm 2 Value	dAL2	5	5
Band Alarm 2 Value	bAL2	5	5
Alarm 2 Hysteresis	AHY2	1	1
Setup Lock Code	Sloc	10	10

LIMIT CONTROLLER (UDC120L) CONFIGURATION RECORD			
Parameter	Lower Display	Factory Default	LEWCO Settings
Input Range/Type	inPt	JF	JF
Scale Range Upper Limit	ruL	1401	1401
Scale Range Lower Limit	rLL	32	32
Decimal Point Position	dPos	1	1
Decimal Point Position	dPos	1	1
Process Variable Offset	OFFS	0	0
Limit Action	Ctrl	Hi	Hi
Set point Upper Limit	SPuL	Range Max	Max Design+20F
Set point Lower Limit	SPLL	Range Min	32
Alarm 1 Type	ALA1	P_Hi	nonE
High Alarm 1 Value	PhA1	Range Max	
Low Alarm 1 Value	PLA1	Range Min	
Deviation Alarm 1 Value	dAL1	5	
Band Alarm 1 Value	bAL1	5	
Alarm 1 Hysteresis	AHY1	1	
Alarm 2 Type	ALA2	P_Lo	nonE
High Alarm 2 Value	PhA2	Range Max	
Low Alarm 2 Value	PLA2	Range Min	
Deviation Alarm 2 Value	dAL2	5	
Band Alarm 2 Value	bAL2	5	
Alarm 2 Hysteresis	AHY2	1	
Output 2 Usage	USE2	A1_d	
Linear Output 2 Range	tYP2	0-10	
Retransmit Output 2 Scale Max.	ro2H	Range Max	
Retransmit Output 2 Scale Min.	ro2L	Range Min	
Output 3 Usage	USE3	0-10	
Linear Output 3 Range	tYP3	Range Max	
Retransmit Output 3 Scale Max.	ro3H	Range Min	
Retransmit Output 3 Scale Min.	ro3L	1	
Display Strategy	diSP	-	1
Comms Protocol	Prot	-	
Bit rate	bAud	-	
Comms Address	Addr	-	
Comms Write	CoEn	-	
Digital Input Usage	diGi	-	
Config Lock Code	Cloc	20	20

Change Display from Fahrenheit to Celsius:

Cycle Power on the Controller:

- ❑ Pull controller from the socket far enough that the display goes off.
- ❑ Wait several seconds.
- ❑ Re-insert controller.
- ❑ Immediately press and hold the “**UP ARROW**” key and the “**SETUP**” key **simultaneously**.
- ❑ Continue to hold both keys until “**1420**” appears on the display.
- ❑ Press the “**DOWN ARROW**” key once to display “**1419.**”
- ❑ Press the “**RESET**” key once to accept.
- ❑ Press the “**UP ARROW**” key and the “**SETUP**” key **simultaneously** again to exit. The display will go blank momentarily then re-appear with decimals between all the characters. The decimals indicate that all parameters have been reset to factory default.

Adjust the Limit Controller **Set point (SP)**:

- ❑ Press the “**UP ARROW**” key and the “**SETUP**” key **simultaneously**.
- ❑ “**ULoc**” should appear in the lower display and a zero should appear in the upper display.
- ❑ Press the “**UP ARROW**” key until “10” appears in the upper display.
- ❑ Press the “**SETUP**” key.
- ❑ “**SP**” should appear in the lower display and the current Set point value should show in the upper display. A small red “s” should appear in the right of the lower display indicating that the controller is in “set up” mode.
- ❑ Press the appropriate “**ARROW**” key to raise or lower the Set point to the desired value.
- ❑ Press the “**SETUP**” key until “**Loc**” appears in the lower display.
- ❑ Press the “**UP ARROW**” key and the “**SETUP**” key **simultaneously** to exit or leave it and it will exit automatically within a minute.