



Model: SWR06EH

### Normal Duty Walk-In Oven

LEWCO Normal-Duty Batch Ovens are designed for common applications, such as pre-heating, drying, and baking. These models offer quality and performance at economical prices. Heavy-duty construction and industry standard components yield durable and reliable equipment. The SWR series features a rear mounted heater box, which is ideal for installations with height restrictions. Each unit is fully assembled, wired, and tested prior to shipment. All LEWCO ovens are manufactured to meet the requirements of NFPA 86.

#### Operating Temperature

- 200°F - 650°F (93°C - 343°C)

#### Heating Source & Capacity

- Electric, low watt density Incoloy® heaters provide years of trouble free service.
- Standard heater bank assemblies are installed in high velocity ductwork to maximize heat transfer.

#### Airflow Pattern

- Horizontal Airflow: Hot air is supplied from one side of the wall and pulled across horizontally to the opposite side wall.

#### General Construction

- 16 ga. aluminized steel interior
- 18 ga. cold rolled steel exterior
- Heat loss is minimized by a unique wall design featuring a welded inner shell and a completely isolated outer frame and covers.

#### Finish

- Blue or gray alkyd enamel
- Optional: Premium finish for corrosive environments

#### Doors

- Heavy-duty doors on an isolated door frame minimize heat loss. Wire core gaskets create a tight seal for efficient heating.
- Explosion venting latches
- Standard: Bi-parting swing doors
- Optional:
  - Vertical lift guillotine door
  - Door windows

#### Floor

- Standard: 12 ga. plate floor
- Optional:
  - 12 ga. plate floor with (1) pair inverted angle track
  - 12 ga. plate floor with (1) pair 6" wide wheel guides
  - Insulated (100 p.s.f. max.)
  - Insulated with (1) pair inverted angle track
  - Insulated with (1) pair 6" wide wheel guides
  - No floor

#### Input Voltage

- Standard 480/3/60
- Please consult factory for other available options.

#### Controls

- Single set-point temperature controller and redundant high-limit controller
- NEMA 12 enclosure with full voltage lockable disconnect switch
- Circulation fan(s) include air proving circuits that are electrically interlocked with the heating circuit.
- Controls are wired to NFPA 70 and 79 electrical standards, and meet the requirements of NFPA 86, Class B ovens.
- Optional:
  - Door Switch
  - Batch Timer
  - Ramp/ Soak controller
  - Data logger/ chart recorder
  - Zero speed switch for fans
  - Composite curing controls

#### Quality Assurance

- Each unit comes complete with a (1) year warranty and is fully assembled, wired, and tested prior to shipment.
- Unit manufactured under ISO 9001 Quality Certified System.

Model (NFPA Class B)	Overall Dimensions			Door Swing Radius	Workspace Dimensions			Workspace Volume (cubic ft.)	Heater Bank (kW)	Circulating Fan (CFM)	Motor (HP)	Air Changes per Minute	Exhaust Fan Capacity (CFM)	Exhaust Motor (HP)	Solvents per Batch (Gals.)	Ships Fully Assembled
	"W	"D	"H		"W	"D	"H									
SWR06EH-48-48-60	81	107	73	24	48	48	60	80	36	1,700	1	21.25	N/A	N/A	0	Yes
SWR06EH-48-48-72	83	107	85	24	48	48	72	96	45	2,000	1 1/2	20.83	N/A	N/A	0	Yes
SWR06EH-48-48-96	85	107	109	24	48	48	96	128	54	2,500	2	19.53	N/A	N/A	0	Yes
SWR06EH-48-72-72	85	135	85	24	48	72	72	144	54	3,000	2	20.83	N/A	N/A	0	Yes
SWR06EH-48-72-96	87	141	109	24	48	72	96	192	63	4,000	3	20.83	N/A	N/A	0	No
SWR06EH-48-96-72	87	165	85	24	48	96	72	192	63	4,000	3	20.83	N/A	N/A	0	No
SWR06EH-48-96-96	91	169	109	24	48	96	96	256	72	5,000	3	19.53	N/A	N/A	0	No
SWR06EH-60-60-60	97	119	73	30	60	60	60	125	45	2,500	2	20.00	N/A	N/A	0	Yes
SWR06EH-60-60-72	97	123	85	30	60	60	72	150	54	3,000	2	20.00	N/A	N/A	0	Yes
SWR06EH-60-60-96	99	129	109	30	60	60	96	200	63	4,000	3	20.00	N/A	N/A	0	Yes
SWR06EH-60-72-72	99	135	85	30	60	72	72	180	54	3,500	3	19.44	N/A	N/A	0	Yes
SWR06EH-60-72-96	101	145	109	30	60	72	96	240	72	4,500	3	18.75	N/A	N/A	0	No
SWR06EH-60-96-96	105	175	109	30	60	96	96	320	81	6,000	3	18.75	N/A	N/A	0	No
SWR06EH-72-72-72	111	141	85	36	72	72	72	216	63	4,000	3	18.52	N/A	N/A	0	No
SWR06EH-72-72-96	115	151	109	36	72	72	96	288	72	5,500	3	19.09	N/A	N/A	0	No
SWR06EH-72-96-96	123	175	109	36	72	96	96	384	90	8,000	5	20.83	N/A	N/A	0	No
SWR06EH-72-120-96	127	199	109	36	72	120	96	480	99	9,000	7 1/2	18.75	N/A	N/A	0	No

Model (NFPA Class A)	Overall Dimensions			Door Swing Radius	Workspace Dimensions			Workspace Volume (cubic ft.)	Heater Bank (kW)	Circulating Fan (CFM)	Motor (HP)	Air Changes per Minute	Exhaust Fan Capacity (CFM)	Exhaust Motor (HP)	Solvents per Batch (Gals.)	Ships Fully Assembled
	"W	"D	"H		"W	"D	"H									
SWR06EH-48-48-60	81	107	124	24	48	48	60	80	45	1,700	1	21.25	62	1/4	0.04	Yes
SWR06EH-48-48-72	83	107	136	24	48	48	72	96	54	2,000	1 1/2	20.83	62	1/4	0.04	Yes
SWR06EH-48-48-96	85	107	160	24	48	48	96	128	63	2,500	2	19.53	62	1/4	0.04	No
SWR06EH-48-72-72	85	135	136	24	48	72	72	144	63	3,000	2	20.83	62	1/4	0.04	Yes
SWR06EH-48-72-96	87	141	160	24	48	72	96	192	72	4,000	3	20.83	62	1/4	0.04	No
SWR06EH-48-96-72	87	165	136	24	48	96	72	192	72	4,000	3	20.83	62	1/4	0.04	Yes
SWR06EH-48-96-96	91	169	160	24	48	96	96	256	81	5,000	3	19.53	62	1/4	0.04	No
SWR06EH-60-60-60	97	119	124	30	60	60	60	125	54	2,500	2	20.00	62	1/4	0.04	Yes
SWR06EH-60-60-72	97	123	136	30	60	60	72	150	63	3,000	2	20.00	62	1/4	0.04	Yes
SWR06EH-60-60-96	99	129	160	30	60	60	96	200	72	4,000	3	20.00	62	1/4	0.04	No
SWR06EH-60-72-72	99	135	136	30	60	72	72	180	63	3,500	3	19.44	62	1/4	0.04	Yes
SWR06EH-60-72-96	101	145	160	30	60	72	96	240	81	4,500	3	18.75	62	1/4	0.04	No
SWR06EH-60-96-96	105	175	160	30	60	96	96	320	108	6,000	3	18.75	100	1/4	0.07	No
SWR06EH-72-72-72	111	141	136	36	72	72	72	216	72	4,000	3	18.52	62	1/4	0.04	Yes
SWR06EH-72-72-96	115	151	160	36	72	72	96	288	81	5,500	3	19.09	62	1/4	0.04	No
SWR06EH-72-96-96	123	175	160	36	72	96	96	384	108	8,000	5	20.83	100	1/4	0.07	No
SWR06EH-72-120-96	127	199	160	36	72	120	96	480	135	9,000	7 1/2	18.75	100	1/4	0.07	No

**NOTE:** Sizes are approximate. LEWCO, Inc. reserves the right to change specifications without notice.

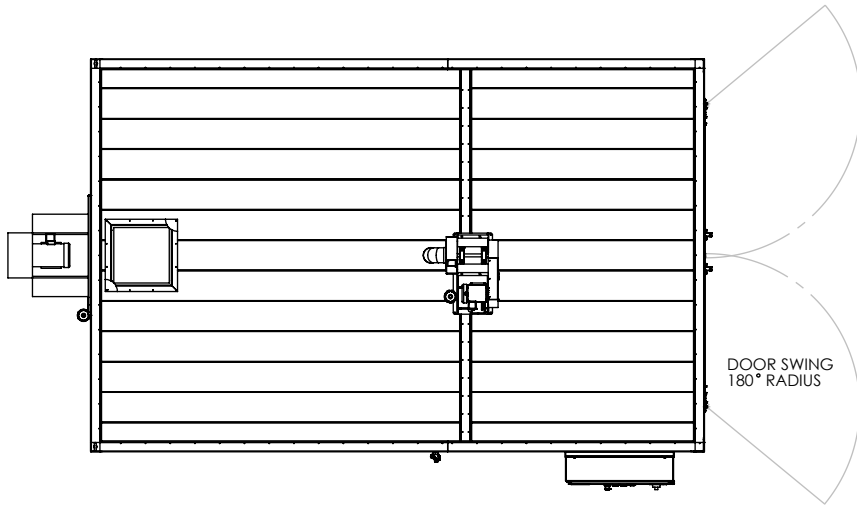

PLAN VIEW

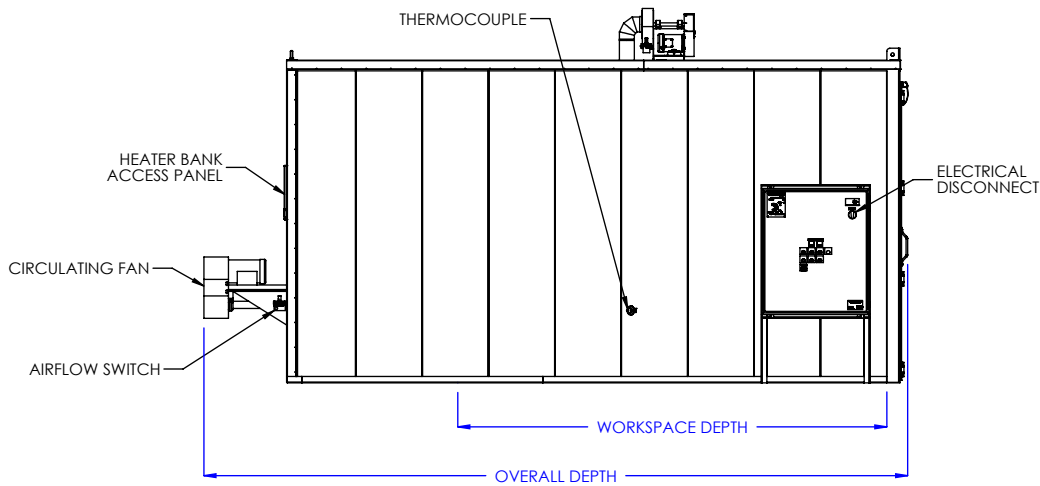

LEFT SIDE ELEVATION

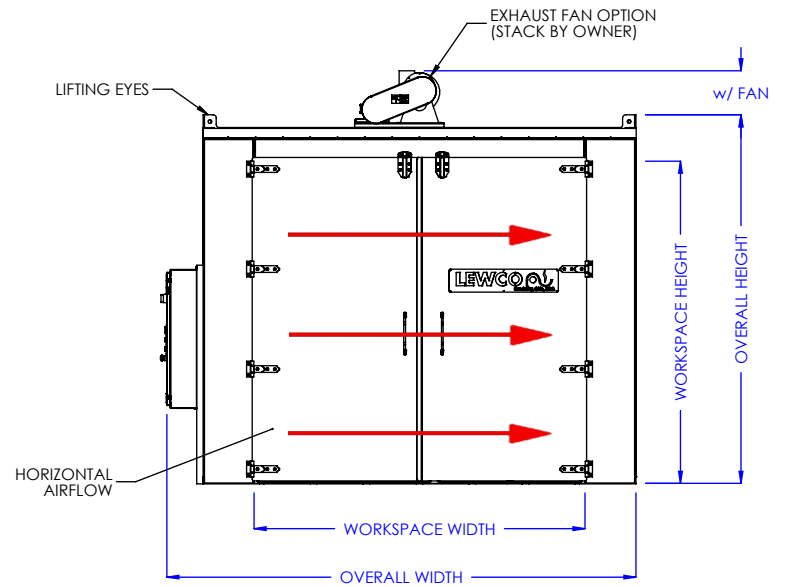

FRONT ELEVATION

MODEL: SWR06EH

DESCRIPTION: NORMAL DUTY WALK-IN OVEN, REAR MOUNT HEATER, 650° F, ELECTRIC, HORIZONTAL AIRFLOW

**WARNING:** OVENS PROCESSING FLAMMABLE VOLATILES OR COMBUSTIBLE MATERIALS ARE CLASSIFIED BY NFPA 86 AS "CLASS A" OVENS AND REQUIRE SPECIFIC SAFETY FEATURES. KNOW THE PROPERTIES OF THE MATERIALS BEING HEATED. EXPLOSION OR FIRE MAY RESULT FROM MISAPPLICATION.

LEWCO, INC. IS COMMITTED TO CONTINUOUS IMPROVEMENT AND RESERVES THE RIGHT TO CHANGE DESIGNS AND SPECIFICATIONS WITHOUT NOTICE.

THIS DRAWING MUST NOT BE COPIED, REPRODUCED OR USED FOR ANY PURPOSE WITHOUT THE WRITTEN CONSENT OF LEWCO, INC. ALL RIGHTS RESERVED.

DATE: 10/9/2017

REV. 001

PAGE: 1 of 1

**LEWCO**

706 LANE ST. SANDUSKY, OH 44870, U.S.A.