



Model: SWT06FD

### Normal Duty Walk-In Oven

LEWCO Normal-Duty Batch Ovens are designed for common applications, such as pre-heating, drying, and baking. These models offer quality and performance at economical prices. Heavy-duty construction and industry standard components yield durable and reliable equipment. The SWT series features a top mounted heater box, which creates a smaller footprint and permits pass-through processing with optional rear doors. Each unit is fully assembled, wired, and tested prior to shipment. All LEWCO ovens are manufactured to meet the requirements of NFPA 86.

#### Operating Temperature

- 200°F - 650°F (93°C -343°C)

#### Heating Source & Capacity

- Direct fired natural gas, modulating burner with direct coupled, digital actuated control valve provides visual indication of valve position.
- High turndown ratio allows rapid heat-up and tight temperature control
- Low CO and NOX emissions
- F.M. compliant fuel train

#### Airflow Pattern

- Dual Airflow: Hot air is supplied from both of the side walls and returned through a top plenum.

#### General Construction

- 16 ga. aluminized steel interior
- 18 ga. cold rolled steel exterior
- Heat loss is minimized by a unique wall design featuring a welded inner shell and a completely isolated outer frame and covers.

#### Finish

- Blue or gray alkyd enamel
- Optional: Premium finish for corrosive environments

#### Doors

- Heavy-duty doors on an isolated door frame minimize heat loss. Wire core gaskets create a tight seal for efficient heating.
- Explosion venting latches
- Standard: Bi-parting swing doors
- Optional:
  - Vertical lift guillotine door
  - Door windows

#### Floor

- Standard: 12 ga. plate floor
- Optional:
  - 12 ga. plate floor with (1) pair inverted angle track
  - 12 ga. plate floor with (1) pair 6" wide wheel guides
  - Insulated (100 p.s.f. max.)
  - Insulated with (1) pair inverted angle track
  - Insulated with (1) pair 6" wide wheel guides
  - No floor

#### Input Voltage

- Standard 480/3/60
- Please consult factory for other available options.

#### Controls

- Single set-point temperature controller and redundant high-limit controller
- NEMA 12 enclosure with full voltage lockable disconnect switch
- Circulation fan(s) include air proving circuits that are electrically interlocked with the heating circuit.
- Controls are wired to NFPA 70 and 79 electrical standards, and meet the requirements of NFPA 86, Class B ovens.
- Optional:
  - Door Switch
  - Batch Timer
  - Ramp/ Soak controller
  - Data logger/ chart recorder
  - Zero speed switch for fans
  - Composite curing controls

#### Quality Assurance

- Each unit comes complete with a (1) year warranty and is fully assembled, wired, and tested prior to shipment.
- Unit manufactured under ISO 9001 Quality Certified System.

Model (NFPA Class B)	Overall Dimensions			Door Swing Radius	Workspace Dimensions			Workspace Volume (cubic ft.)	Burner (BTU/ Hr)	Circulating Fan (CFM)	Motor (HP)	Air Changes per Minute	Exhaust Fan Capacity (CFM)	Exhaust Motor (HP)	Solvents per Batch (Gals.)	Ships Fully Assembled
	"W	"D	"H		"W	"D	"H									
SWT06FD-48-48-60 *	79	60	118	24"	48	48	60	80	200,000	1,700	1	21.25	250	1/4	0	Yes
SWT06FD-48-48-72 *	79	60	130	24"	48	48	72	96	200,000	2,000	1 1/2	20.83	250	1/4	0	Yes
SWT06FD-48-48-96 *	79	60	154	24"	48	48	96	128	200,000	2,500	2	19.53	250	1/4	0	Yes
SWT06FD-60-60-60 *	91	72	118	30"	60	60	60	125	200,000	2,500	2	20.00	250	1/4	0	Yes
SWT06FD-60-60-72 *	91	72	135	30"	60	60	72	150	200,000	3,000	2	20.00	250	1/4	0	Yes
SWT06FD-60-60-96 *	91	72	165	30"	60	60	96	200	400,000	4,000	3	20.00	250	1/4	0	Yes
SWT06FD-72-72-72 *	103	84	141	36"	72	72	72	216	400,000	4,000	3	18.52	250	1/4	0	Yes
SWT06FD-72-72-96 *	105	84	173	36"	72	72	96	288	400,000	5,500	3	19.10	250	1/4	0	No
SWT06FD-72-120-96	111	132	176	36"	72	120	96	480	400,000	9,000	7 1/2	18.75	250	1/4	0	No
SWT06FD-84-84-84	119	96	162	42"	84	84	84	343	400,000	7,000	5	20.41	250	1/4	0	Yes
SWT06FD-84-96-84	121	108	163	42"	84	96	84	392	400,000	8,000	5	20.41	250	1/4	0	Yes
SWT06FD-84-120-84	123	132	168	42"	84	120	84	490	700,000	10,000	8	20.41	500	1	0	No
SWT06FD-84-120-96	125	132	186	42"	84	120	96	560	700,000	12,000	7 1/2	21.43	500	1	0	No
SWT06FD-96-96-96	135	108	180	48"	96	96	96	512	700,000	10,000	7 1/2	19.53	500	1	0	No
SWT06FD-96-120-96	137	132	186	48"	96	120	96	640	700,000	12,000	7 1/2	18.75	500	1	0	No
SWT06FD-96-144-96	141	156	193	48"	96	144	96	768	700,000	16,000	10	20.83	500	1	0	No
SWT06FD-96-168-96	143	180	194	48"	96	168	96	896	700,000	18,000	15	20.09	500	1	0	No
SWT06FD-96-192-96	145	204	201	48"	96	192	96	1,024	700,000	20,000	15	19.53	500	1	0	No
SWT06FD-96-240-96	147	252	207	48"	96	240	96	1,280	1,000,000	24,000	15	18.75	750	1	0	No
SWT06FD-96-240-120	151	252	163	48"	96	240	120	1,600	1,500,000	30,000	20	18.75	1,000	2	0	No
SWT06FD-96-288-96	151	300	216	48"	96	288	96	1,536	1,500,000	30,000	20	19.53	1,000	2	0	No
SWT06FD-96-288-120	159	300	252	48"	96	288	120	1,920	1,500,000	40,000	20	20.83	1,000	2	0	No
SWT06FD-120-120-96	165	132	193	60"	120	120	96	800	700,000	16,000	10	20.00	500	1	0	No
SWT06FD-120-120-120	169	132	225	60"	120	120	120	1,000	700,000	20,000	15	20.00	500	1	0	No
SWT06FD-120-144-96	167	156	194	60"	120	144	96	960	700,000	18,000	15	18.75	500	1	0	No
SWT06FD-120-144-120	171	156	231	60"	120	144	120	1,200	1,000,000	24,000	15	20.00	750	1	0	No
SWT06FD-120-168-96	169	180	206	60"	120	168	96	1,120	1,000,000	22,000	15	19.64	750	1	0	No
SWT06FD-120-168-120	173	180	232	60"	120	168	120	1,400	1,000,000	26,000	15	18.57	750	1	0	No
SWT06FD-120-192-96	171	204	207	60"	120	192	96	1,280	1,000,000	24,000	15	18.75	750	1	0	No
SWT06FD-120-192-120	175	204	240	60"	120	192	120	1,600	1,500,000	30,000	20	18.75	1,000	1 1/2	0	No
SWT06FD-120-240-96	183	252	228	60"	120	240	96	1,600	1,500,000	30,000	20	18.75	1,000	1 1/2	0	No
SWT06FD-120-240-120	183	252	252	60"	120	240	120	2,000	1,500,000	40,000	20	20	1,000	1 1/2	0	No
SWT06FD-120-288-96	183	300	228	60"	120	288	96	1,920	1,500,000	40,000	20	20.83	1,000	1 1/2	0	No
SWT06FD-120-288-120	193	300	257	60"	120	288	120	2,400	1,500,000	50,000	20	20.83	1,000	1 1/2	0	No

\* Indicates Configuration Style #1. Refer to drawings on page 3 of 4

**NOTE: Sizes are approximate. LEWCO, Inc. reserves the right to change specifications without notice.**

Model (NFPA Class A)	Overall Dimensions			Door Swing Radius	Workspace Dimensions			Workspace Volume (cubic ft.)	Burner (BTU/ Hr)	Circulating Fan (CFM)	Motor (HP)	Air Changes per Minute	Exhaust Fan Capacity (CFM)	Exhaust Motor (HP)	Solvents per Batch (Gals.)	Ships Fully Assembled
	"W	"D	"H		"W	"D	"H									
SWT06FD-48-48-60 *	79	60	118	24"	48	48	60	80	200,000	1,700	1	21.25	250	1/4	0.04	Yes
SWT06FD-48-48-72 *	79	60	130	24"	48	48	72	96	200,000	2,000	2	20.83	250	1/4	0.04	Yes
SWT06FD-48-48-96 *	79	60	154	24"	48	48	96	128	200,000	2,500	2	19.53	250	1/4	0.04	Yes
SWT06FD-60-60-60 *	91	72	118	30"	60	60	60	125	200,000	2,500	2	20.00	250	1/4	0.04	Yes
SWT06FD-60-60-72 *	91	72	135	30"	60	60	72	150	200,000	3,000	2	20.00	250	1/4	0.04	Yes
SWT06FD-60-60-96 *	91	72	165	30"	60	60	96	200	400,000	4,000	3	20.00	500	1	0.04	Yes
SWT06FD-72-72-72 *	103	84	141	36"	72	72	72	216	400,000	4,000	3	18.52	500	1	0.04	Yes
SWT06FD-72-72-96 *	105	84	173	36"	72	72	96	288	400,000	5,500	3	19.10	500	1	0.04	No
SWT06FD-72-120-96	111	132	176	36"	72	120	96	480	400,000	9,000	7 1/2	18.75	500	1	0.07	No
SWT06FD-84-84-84	119	96	162	42"	84	84	84	343	400,000	7,000	5	20.41	500	1	0.07	Yes
SWT06FD-84-96-84	121	108	163	42"	84	96	84	392	400,000	8,000	5	20.41	500	1	0.07	No
SWT06FD-84-120-84	123	132	168	42"	84	120	84	490	700,000	10,000	8	20.41	750	1	0.18	No
SWT06FD-84-120-96	125	132	186	42"	84	120	96	560	700,000	12,000	7 1/2	21.43	750	1	0.18	No
SWT06FD-96-96-96	135	108	180	48"	96	96	96	512	700,000	10,000	7 1/2	19.53	750	1	0.18	No
SWT06FD-96-120-96	137	132	186	48"	96	120	96	640	700,000	12,000	7 1/2	18.75	750	1	0.18	No
SWT06FD-96-144-96	141	156	193	48"	96	144	96	768	700,000	16,000	10	20.83	750	1	0.18	No
SWT06FD-120-120-96	165	132	193	60"	120	120	96	800	700,000	16,000	10	20.00	750	1	0.18	No
SWT06FD-120-120-120	169	132	225	60"	120	120	120	1,000	700,000	20,000	15	20.00	750	1	0.18	No
SWT06FD-120-144-96	167	156	194	60"	120	144	96	960	700,000	18,000	15	18.75	750	1	0.18	No
SWT06FD-120-144-120	171	156	161	60"	120	144	120	1,200	1,000,000	24,000	15	20.00	1,000	1 1/2	0.18	No
SWT06FD-120-168-96	169	180	206	60"	120	168	96	1,120	1,000,000	22,000	15	19.64	1,000	1 1/2	0.18	No
SWT06FD-120-168-120	173	180	232	60"	120	168	120	1,400	1,000,000	26,000	15	18.57	1,500	2	0.37	No
SWT06FD-120-192-96	171	204	207	60"	120	192	96	1,280	1,000,000	24,000	15	18.75	1,500	2	0.37	No
SWT06FD-120-192-120	175	204	240	60"	120	192	120	1,600	1,500,000	30,000	20	18.75	2,000	1	0.56	No
SWT06FD-120-240-96	175	252	216	60"	120	240	96	1,600	1,500,000	30,000	20	18.75	2,000	1	0.56	No
SWT06FD-120-240-120	183	252	252	60"	120	240	120	2,000	1,500,000	40,000	20	20.00	2,000	1	0.56	No
SWT06FD-120-288-96	183	300	228	60"	120	288	96	1,920	1,500,000	40,000	20	20.83	2,000	1	0.56	No
SWT06FD-120-288-120	193	300	257	60"	120	288	120	2,400	1,500,000	50,000	20	20.83	2,000	1	0.56	No

\* Indicates Configuration Style #1. Refer to drawings on page 3 of 4

**NOTE: Sizes are approximate. LEWCO, Inc. reserves the right to change specifications without notice.**

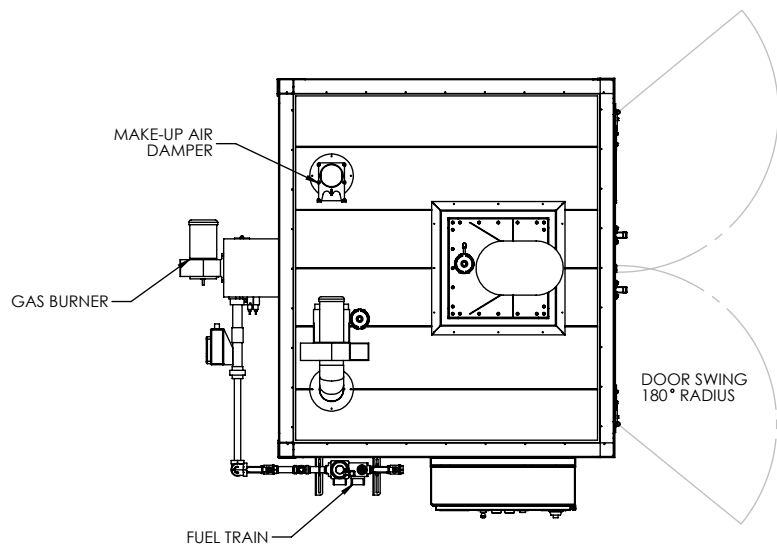

**PLAN VIEW**

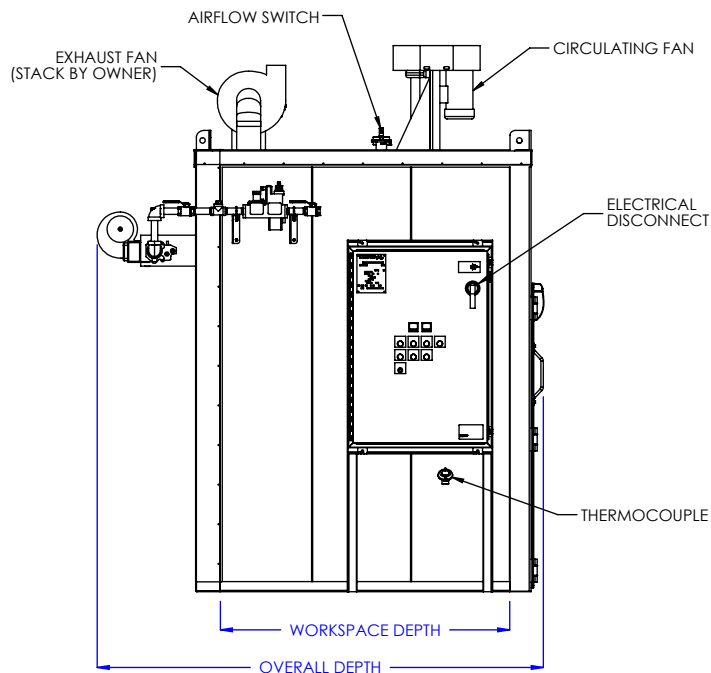

**LEFT SIDE ELEVATION**

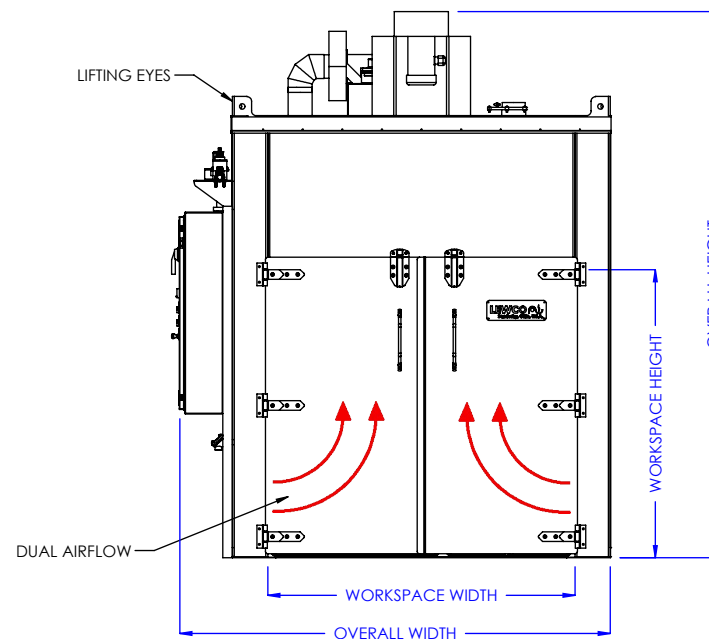

**FRONT ELEVATION**

MODEL: SWT06FD

DESCRIPTION: NORMAL DUTY WALK-IN OVEN, TOP MOUNT HEATER, 650°F, FUEL-FIRED, DUAL AIRFLOW

**WARNING:** OVENS PROCESSING FLAMMABLE VOLATILES OR COMBUSTIBLE MATERIALS ARE CLASSIFIED BY NFPA 86 AS "CLASS A" OVENS AND REQUIRE SPECIFIC SAFETY FEATURES. KNOW THE PROPERTIES OF THE MATERIALS BEING HEATED. EXPLOSION OR FIRE MAY RESULT FROM MISAPPLICATION.

LEWCO, INC. IS COMMITTED TO CONTINUOUS IMPROVEMENT AND RESERVES THE RIGHT TO CHANGE DESIGNS AND SPECIFICATIONS WITHOUT NOTICE.

THIS DRAWING MUST NOT BE COPIED, REPRODUCED OR USED FOR ANY PURPOSE WITHOUT THE WRITTEN CONSENT OF LEWCO, INC. ALL RIGHTS RESERVED.

DATE: 10/11/2017

REV. 001

PAGE: 4 of 5



706 LANE ST. SANDUSKY, OH 44870, U.S.A.

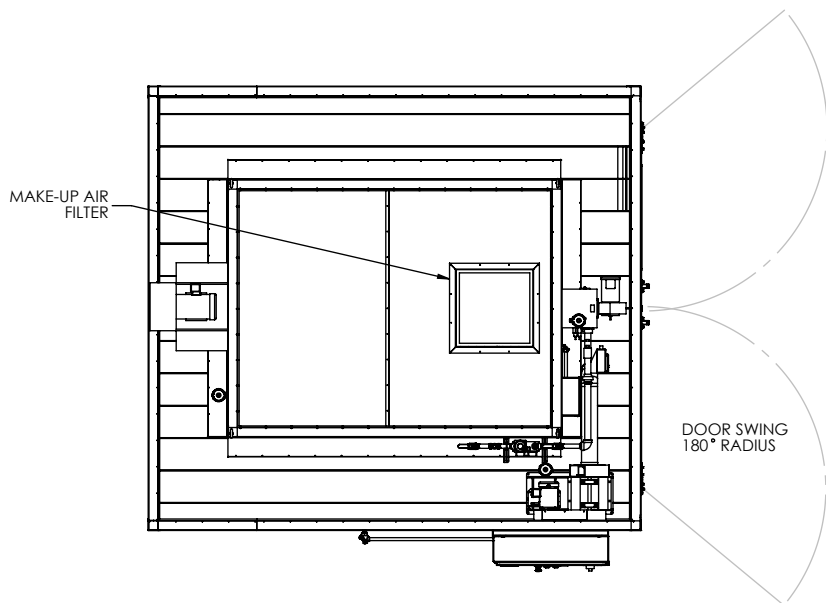

PLAN VIEW

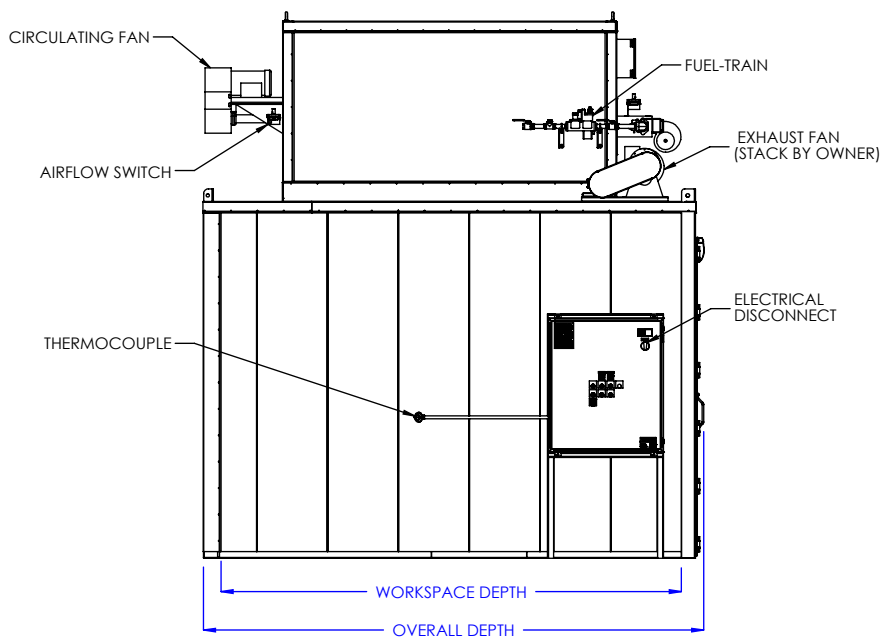

LEFT SIDE ELEVATION

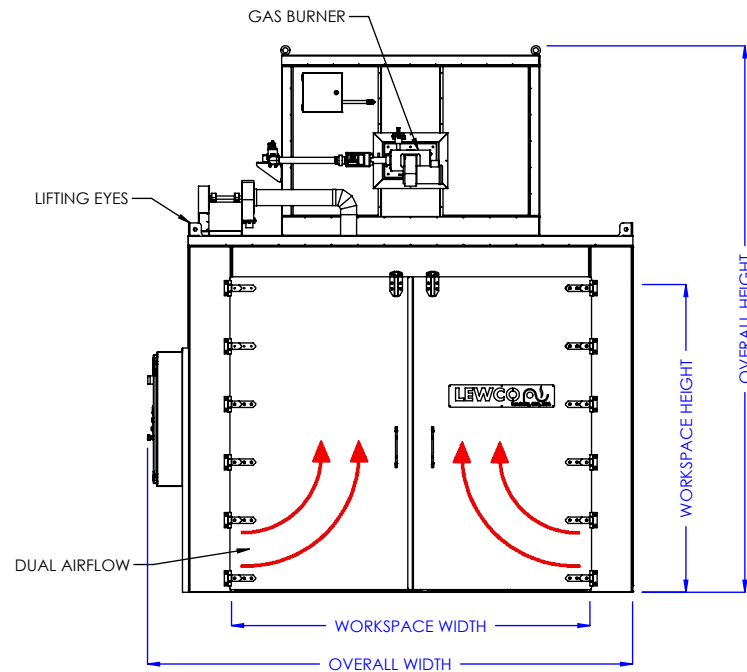

FRONT ELEVATION

MODEL: SWT06FD

DESCRIPTION: NORMAL DUTY WALK-IN OVEN, TOP MOUNT HEATER, 650°F, FUEL-FIRED, DUAL AIRFLOW

**WARNING:** OVENS PROCESSING FLAMMABLE VOLATILES OR COMBUSTIBLE MATERIALS ARE CLASSIFIED BY NFPA 86 AS "CLASS A" OVENS AND REQUIRE SPECIFIC SAFETY FEATURES. KNOW THE PROPERTIES OF THE MATERIALS BEING HEATED. EXPLOSION OR FIRE MAY RESULT FROM MISAPPLICATION.

LEWCO, INC. IS COMMITTED TO CONTINUOUS IMPROVEMENT AND RESERVES THE RIGHT TO CHANGE DESIGNS AND SPECIFICATIONS WITHOUT NOTICE.

THIS DRAWING MUST NOT BE COPIED, REPRODUCED OR USED FOR ANY PURPOSE WITHOUT THE WRITTEN CONSENT OF LEWCO, INC. ALL RIGHTS RESERVED.

DATE: 7/6/2017

REV. 001

PAGE: 5 of 5



706 LANE ST. SANDUSKY, OH 44870, U.S.A.