



Model: SWT06ED

Normal Duty Walk-In Oven

LEWCO Normal-Duty Batch Ovens are designed for common applications, such as pre-heating, drying, and baking. These models offer quality and performance at economical prices. Heavy-duty construction and industry standard components yield durable and reliable equipment. The SWT series features a top mounted heater box, which creates a smaller footprint and permits pass-through processing with optional rear doors. Each unit is fully assembled, wired, and tested prior to shipment. All LEWCO ovens are manufactured to meet the requirements of NFPA 86.

Operating Temperature

- 150°F - 650°F (66°C -343°C)

Heating Source & Capacity

- Electric, low watt density Incoloy® heaters provide years of trouble free service.
- Standard heater bank assemblies are installed in high velocity ductwork to maximize heat transfer.

Airflow Pattern

- Dual Airflow: Hot air is supplied from both of the side walls and returned through a top plenum.

General Construction

- 16 ga. aluminized steel interior
- 18 ga. cold rolled steel exterior
- Heat loss is minimized by a unique wall design featuring a welded inner shell and a completely isolated outer frame and covers.

Finish

- Blue or gray alkyd enamel
- Optional: Premium finish for corrosive environments

Doors

- Heavy-duty doors on an isolated door frame minimize heat loss. Wire core gaskets create a tight seal for efficient heating.
- Explosion venting latches
- Standard: Bi-parting swing doors
- Optional:
 - Vertical lift guillotine door
 - Door windows

Floor

- Standard: 12 ga. plate floor
- Optional:
 - 12 ga. plate floor with (1) pair inverted angle track
 - 12 ga. plate floor with (1) pair 6" wide wheel guides
 - Insulated (100 p.s.f. max.)
 - Insulated with (1) pair inverted angle track
 - Insulated with (1) pair 6" wide wheel guides
 - No floor

Input Voltage

- Standard 480/3/60
- Please consult factory for other available options.

Controls

- Single set-point temperature controller and redundant high-limit controller
- NEMA 12 enclosure with full voltage lockable disconnect switch
- Circulation fan(s) include air proving circuits that are electrically interlocked with the heating circuit.
- Controls are wired to NFPA 70 and 79 electrical standards, and meet the requirements of NFPA 86, Class B ovens.
- Optional:
 - Door Switch
 - Batch Timer
 - Ramp/ Soak controller
 - Data logger/ chart recorder
 - Zero speed switch for fans
 - Composite curing controls

Quality Assurance

- Each unit comes complete with a (1) year warranty and is fully assembled, wired, and tested prior to shipment.
- Unit manufactured under ISO 9001 Quality Certified System.

Model (NFPA Class B)	Overall Dimensions			Door Swing Radius	Workspace Dimensions			Workspace Volume (cubic ft.)	Heater Bank (kW)	Circulating Fan(s) (CFM)	Motor(s) (HP)	Air Changes per Minute	Exhaust Fan Capacity (CFM)	Exhaust Motor (HP)	Solvents per Batch (Gals.)	Ships Fully Assembled
	"W	"D	"H		"W	"D	"H									
SWT06ED-48-48-60 *	79	61	123	24"	48	48	60	80	36	1,700	1	21.25	N/A	N/A	0	Yes
SWT06ED-48-48-72 *	81	61	135	24"	48	48	72	96	45	2,000	1 1/2	20.83	N/A	N/A	0	Yes
SWT06ED-48-48-96 *	83	61	159	24"	48	48	96	128	54	2,500	2	19.53	N/A	N/A	0	Yes
SWT06ED-60-60-60 *	95	73	123	30"	60	60	60	125	45	2,500	2	20.00	N/A	N/A	0	Yes
SWT06ED-60-60-72 *	95	73	136	30"	60	60	72	150	54	3,000	2	20.00	N/A	N/A	0	Yes
SWT06ED-60-60-96 *	97	73	163	30"	60	60	96	200	63	4,000	3	20.00	N/A	N/A	0	No
SWT06ED-72-72-72 *	109	85	139	36"	72	72	72	216	63	4,000	3	18.52	N/A	N/A	0	Yes
SWT06ED-72-72-96 *	113	85	169	36"	72	72	96	288	72	5,500	3	19.09	N/A	N/A	0	No
SWT06ED-72-120-96	125	133	169	36"	72	120	96	480	99	9,000	7 1/2	18.75	N/A	N/A	0	No
SWT06ED-84-84-84	129	97	157	42"	84	84	84	343	81	7,000	5	20.41	N/A	N/A	0	No
SWT06ED-84-96-84	133	109	157	42"	84	96	84	392	90	8,000	5	20.41	N/A	N/A	0	No
SWT06ED-84-120-84	137	133	162	42"	84	120	84	490	99	10,000	8	20.41	N/A	N/A	0	No
SWT06ED-84-120-96	141	133	176	42"	84	120	96	560	108	12,000	7 1/2	21.43	N/A	N/A	0	No
SWT06ED-96-96-96	149	109	174	48"	96	96	96	512	108	10,000	7 1/2	19.53	N/A	N/A	0	Yes
SWT06ED-96-120-96	153	133	176	48"	96	120	96	640	126	12,000	7 1/2	18.75	N/A	N/A	0	Yes
SWT06ED-96-144-96	161	157	182	48"	96	144	96	768	144	16,000	10	20.83	N/A	N/A	0	Yes
SWT06ED-96-168-96	167	181	182	48"	96	168	96	896	162	18,000	15	20.09	N/A	N/A	0	No
SWT06ED-96-192-96	169	205	184	48"	96	192	96	1,024	171	20,000	15	19.53	N/A	N/A	0	No
SWT06ED-96-240-96	173	253	151	48"	96	240	96	1,280	207	24,000	15	18.75	N/A	N/A	0	No
SWT06ED-96-240-120	183	253	177	48"	96	240	120	1,600	234	30,000	20	19.75	N/A	N/A	0	No
SWT06ED-96-288-96	183	301	153	48"	96	288	96	1,536	234	30,000	20	19.53	N/A	N/A	0	No
SWT06ED-96-288-120	159	301	225	48"	96	288	120	1,910	288	40,000	20	20.83	N/A	N/A	0	No
SWT06ED-120-120-96	185	133	182	60"	120	120	96	800	144	16,000	10	20.00	N/A	N/A	0	No
SWT06ED-120-120-120	193	133	208	60"	120	120	120	1,000	162	20,000	15	18.00	N/A	N/A	0	No
SWT06ED-120-144-96	191	157	182	60"	120	144	96	960	162	18,000	15	18.75	N/A	N/A	0	No
SWT06ED-120-144-120	197	157	175	60"	120	144	120	1,200	189	24,000	15	20.00	N/A	N/A	0	No
SWT06ED-120-168-96	193	181	151	60"	120	168	96	1,120	180	22,000	15	19.64	N/A	N/A	0	No
SWT06ED-120-168-120	203	181	175	60"	120	168	120	1,400	207	26,000	15	18.57	N/A	N/A	0	No
SWT06ED-120-192-96	197	205	151	60"	120	192	96	1,280	198	24,000	15	18.75	N/A	N/A	0	No
SWT06ED-120-192-120	207	205	177	60"	120	192	120	1,600	225	16000(x2)	10(x2)	20	N/A	N/A	0	No
SWT06ED-120-240-96	207	253	153	60"	120	240	96	1,600	234	16000(x2)	10(x2)	20	N/A	N/A	0	No
SWT06ED-120-240-120	183	253	225	60"	120	240	120	2,000	261	20000(x2)	15(x2)	20	N/A	N/A	0	No
SWT06ED-120-288-96	183	301	201	60"	120	288	96	1,920	288	20000(x2)	15(x2)	20.83	N/A	N/A	0	No
SWT06ED-120-288-120	193	301	230	60"	120	288	120	2,400	297	26000(x2)	15(x2)	21.67	N/A	N/A	0	No

* Indicates Configuration Style #1. Refer to drawings on page 4 of 5

NOTE: Sizes are approximate. LEWCO, Inc. reserves the right to change specifications without notice.

Model (NFPA Class A)	Overall Dimensions			Door Swing Radius	Workspace Dimensions			Workspace Volume (cubic ft.)	Heater Bank (kW)	Circulating Fan(s) (CFM)	Motor(s) (HP)	Air Changes per Minute	Exhaust Fan Capacity (CFM)	Exhaust Motor (HP)	Solvents per Batch (Gals.)	Ships Fully Assembled
	"W	"D	"H		"W	"D	"H									
SWT06ED-48-48-60 *	79	61	174	24"	48	48	60	80	45	1,700	1	21.25	62	1/4	0.04	Yes
SWT06ED-48-48-72 *	81	61	186	24"	48	48	72	96	54	2,000	1 1/2	20.83	62	1/4	0.04	Yes
SWT06ED-48-48-96 *	83	61	210	24"	48	48	96	128	63	2,500	2	19.53	62	1/4	0.04	Yes
SWT06ED-60-60-60 *	95	73	174	30"	60	60	60	125	54	2,500	2	20.00	62	1/4	0.04	Yes
SWT06ED-60-60-72 *	95	73	187	30"	60	60	72	150	63	3,000	2	20.00	62	1/4	0.04	Yes
SWT06ED-60-60-96 *	97	73	214	30"	60	60	96	200	72	4,000	3	20.00	62	1/4	0.04	No
SWT06ED-72-72-72 *	109	85	190	36"	72	72	72	216	72	4,000	3	18.52	62	1/4	0.04	No
SWT06ED-72-72-96 *	113	85	220	36"	72	72	96	288	81	5,500	3	19.09	62	1/4	0.04	No
SWT06ED-72-120-96	125	133	220	36"	72	120	96	480	135	9,000	7 1/2	18.75	100	1/4	0.07	No
SWT06ED-84-84-84	129	97	208	42"	84	84	84	343	108	7,000	5	20.41	100	1/4	0.07	No
SWT06ED-84-96-84	133	109	208	42"	84	96	84	392	108	8,000	5	20.41	100	1/4	0.07	No
SWT06ED-84-120-84	137	133	213	42"	84	120	84	490	162	10,000	7 1/2	20.41	250	1/4	0.18	No
SWT06ED-84-120-96	141	133	227	42"	84	120	96	560	162	12,000	7 1/2	21.43	250	1/4	0.18	No
SWT06ED-96-96-96	149	109	225	48"	96	96	96	512	162	10,000	7 1/2	19.53	250	1/4	0.18	No
SWT06ED-96-120-96	153	133	227	48"	96	120	96	640	171	12,000	7 1/2	18.75	250	1/4	0.18	No
SWT06ED-96-144-96	161	157	233	48"	96	144	96	768	189	16,000	10	20.83	250	1/4	0.18	No
SWT06ED-120-120-96	185	133	233	60"	120	120	96	800	189	16,000	10	20.00	250	1/4	0.18	No
SWT06ED-120-120-120	193	133	259	60"	120	120	120	1,000	225	20,000	15	20.00	250	1/4	0.18	No
SWT06ED-120-144-96	191	157	233	60"	120	144	96	960	207	18,000	15	18.75	250	1/4	0.18	No
SWT06ED-120-144-120	197	157	226	60"	120	144	120	1,200	234	24,000	15	20.00	250	1/4	0.18	No
SWT06ED-120-168-96	193	181	202	60"	120	168	96	1,120	225	22,000	15	19.64	250	1/4	0.18	No
SWT06ED-120-168-120	203	181	226	60"	120	168	120	1,400	288	26,000	15	18.57	750	1	0.37	No
SWT06ED-120-192-96	197	205	202	60"	120	192	96	1,280	288	24,000	15	18.75	750	1	0.37	No
SWT06ED-120-192-120	207	205	228	60"	120	192	120	1,600	225	16000(x2)	10(x2)	20	1000	1 1/2	2/5	No
SWT06ED-120-240-96	183	253	252	60"	120	240	96	1,600	297	16000(x2)	10(x2)	20	1000	1 1/2	2/5	No
SWT06ED-120-240-120	183	253	252	60"	120	240	120	2,000	297	20000(x2)	15(x2)	20	1,000	1 1/2	0.4	No
SWT06ED-120-288-96	183	301	300	60"	120	288	96	1,920	297	20000(x2)	15(x2)	20.83	1,000	1 1/2	0.4	No
SWT06ED-120-288-120	183	301	300	60"	120	288	120	2,400	297	24000(x2)	15(x2)	20	1,000	1 1/2	0.4	No
SWT06ED-120-336-96	183	349	348	60"	120	336	96	2,240	297	24000(x2)	15(x2)	21.42	1,000	1 1/2	0.4	No
SWT06ED-120-336-120	193	349	348	60"	120	336	120	2,800	297	28000(x2)	15(x2)	20.00	1,000	1 1/2	0.4	No

* Indicates Configuration Style #1. Refer to drawings on page 4 of 5

NOTE: Sizes are approximate. LEWCO, Inc. reserves the right to change specifications without notice.

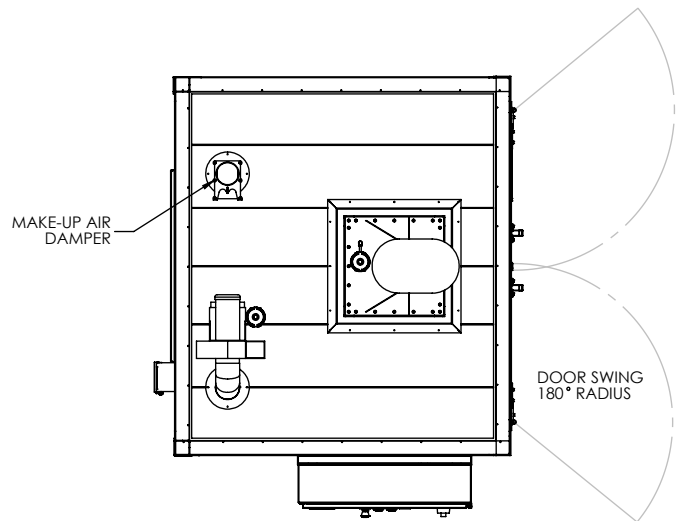

PLAN VIEW

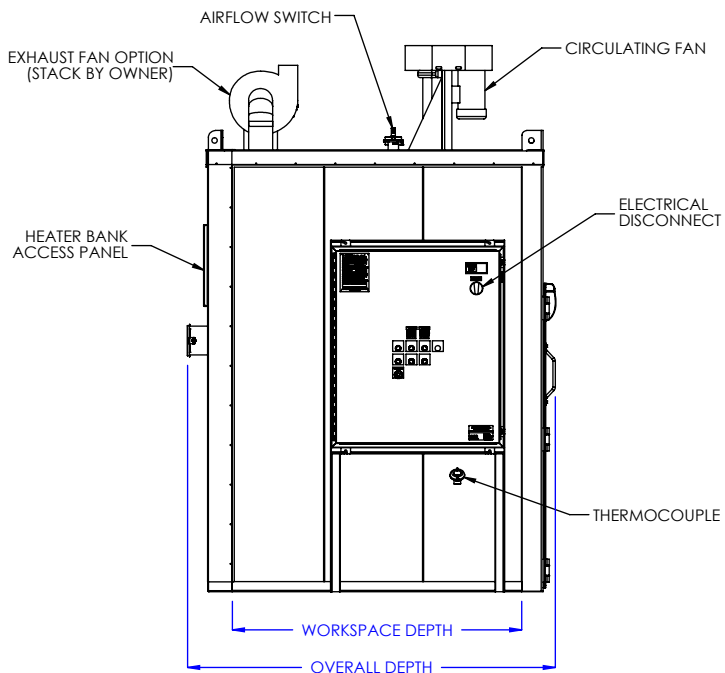

LEFT SIDE ELEVATION

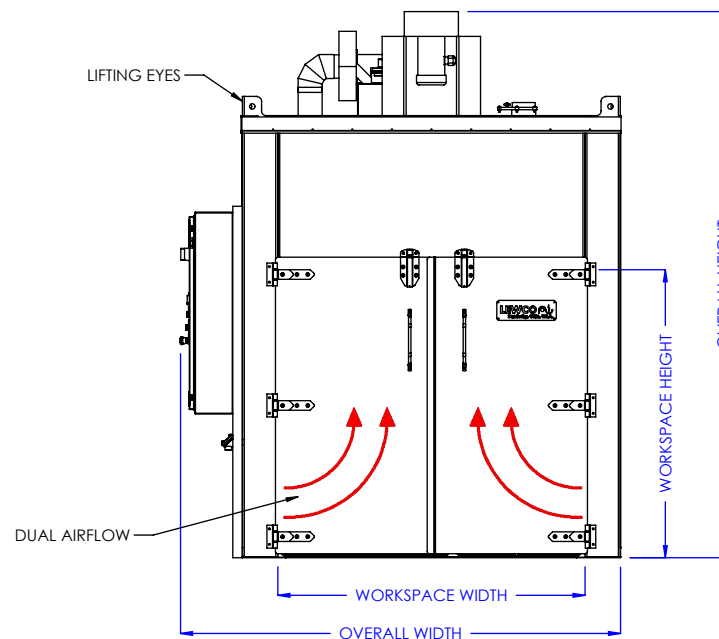

FRONT ELEVATION

MODEL: SWT06ED

DESCRIPTION: NORMAL DUTY WALK-IN OVEN, TOP MOUNT HEATER, 650°F, ELECTRIC, DUAL AIRFLOW

WARNING: OVENS PROCESSING FLAMMABLE VOLATILES OR COMBUSTIBLE MATERIALS ARE CLASSIFIED BY NFPA 86 AS "CLASS A" OVENS AND REQUIRE SPECIFIC SAFETY FEATURES. KNOW THE PROPERTIES OF THE MATERIALS BEING HEATED. EXPLOSION OR FIRE MAY RESULT FROM MISAPPLICATION.

LEWCO, INC. IS COMMITTED TO CONTINUOUS IMPROVEMENT AND RESERVES THE RIGHT TO CHANGE DESIGNS AND SPECIFICATIONS WITHOUT NOTICE.

THIS DRAWING MUST NOT BE COPIED, REPRODUCED OR USED FOR ANY PURPOSE WITHOUT THE WRITTEN CONSENT OF LEWCO, INC. ALL RIGHTS RESERVED.

DATE: 7/5/2017

REV. 001

PAGE: 4 of 5



706 LANE ST. SANDUSKY, OH 44870, U.S.A.

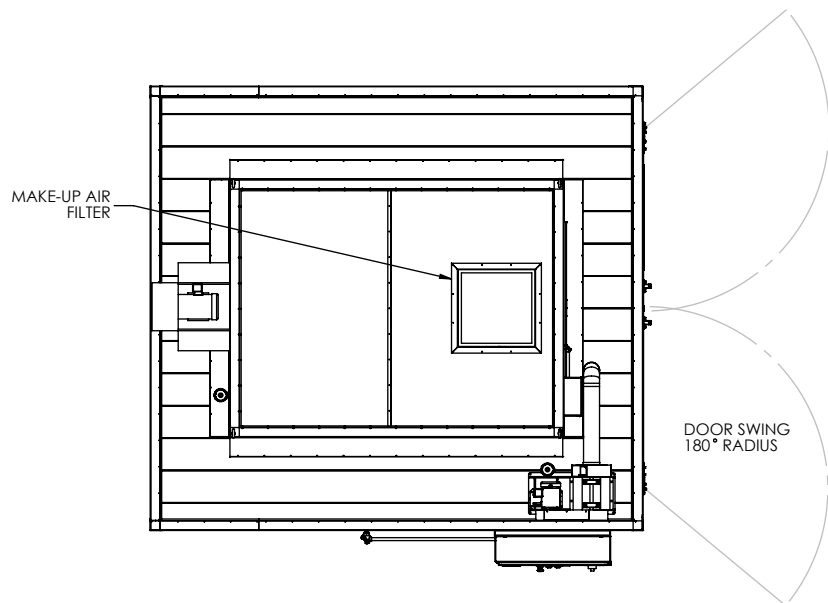

PLAN VIEW

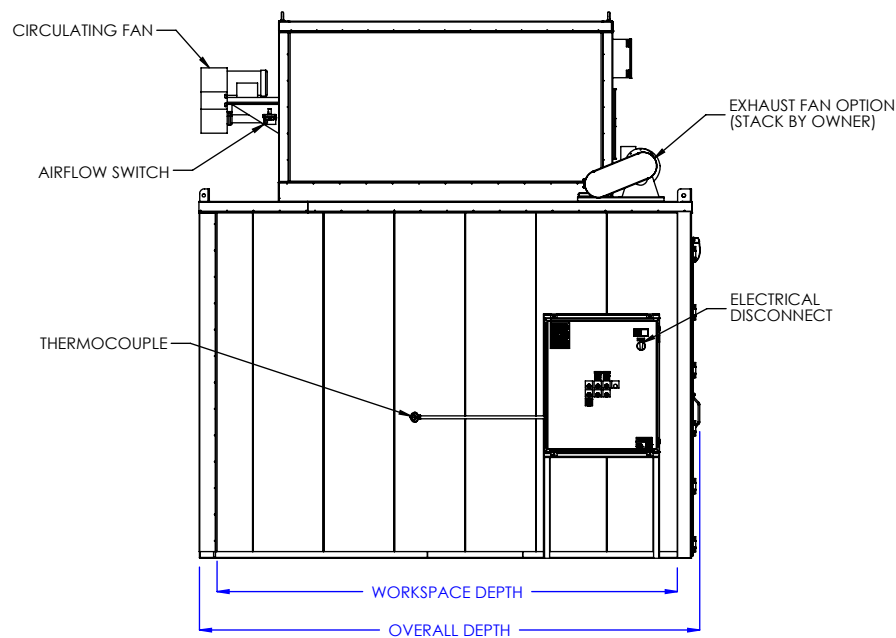

LEFT SIDE ELEVATION

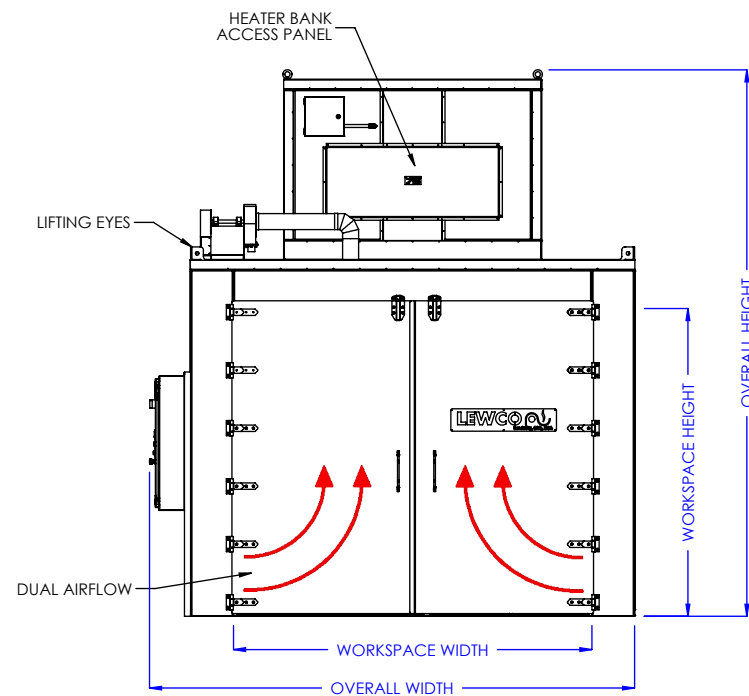

FRONT ELEVATION

MODEL: SWT06ED

DESCRIPTION: NORMAL DUTY WALK-IN OVEN, TOP MOUNT HEATER, 650°F, ELECTRIC, DUAL AIRFLOW

WARNING: OVENS PROCESSING FLAMMABLE VOLATILES OR COMBUSTIBLE MATERIALS ARE CLASSIFIED BY NFPA 86 AS "CLASS A" OVENS AND REQUIRE SPECIFIC SAFETY FEATURES. KNOW THE PROPERTIES OF THE MATERIALS BEING HEATED. EXPLOSION OR FIRE MAY RESULT FROM MISAPPLICATION.

LEWCO, INC. IS COMMITTED TO CONTINUOUS IMPROVEMENT AND RESERVES THE RIGHT TO CHANGE DESIGNS AND SPECIFICATIONS WITHOUT NOTICE.

THIS DRAWING MUST NOT BE COPIED, REPRODUCED OR USED FOR ANY PURPOSE WITHOUT THE WRITTEN CONSENT OF LEWCO, INC. ALL RIGHTS RESERVED.

DATE: 7/5/2017

REV. 001

PAGE: 5 of 5



706 LANE ST. SANDUSKY, OH 44870, U.S.A.