



Model: SWR06FD

### Normal Duty Walk-In Oven

LEWCO Normal-Duty Batch Ovens are designed for common applications, such as pre-heating, drying, and baking. These models offer quality and performance at economical prices. Heavy-duty construction and industry standard components yield durable and reliable equipment. The SWR series features a rear-mounted heater box, which is ideal for installations with height restrictions. Each unit is fully assembled, wired, and tested prior to shipment. All LEWCO ovens are manufactured to meet the requirements of NFPA 86.

#### Operating Temperature

- 200°F - 650°F (93°C -343°C)

#### Heating Source & Capacity

- Direct fired natural gas, modulating burner with direct coupled, digital actuated control valve provides visual indication of valve position.
- High turndown ratio allows rapid heat-up and tight temperature control
- Low CO and NOX emissions
- F.M. compliant fuel train

#### Airflow Pattern

- Dual Airflow: Hot air is supplied from both side walls and returned through a top plenum.

#### General Construction

- 16 ga. aluminized steel interior
- 18 ga. cold rolled steel exterior
- Heat loss is minimized by a unique wall design featuring a welded inner shell and a completely isolated outer frame and covers.

#### Finish

- Blue or gray alkyd enamel
- Optional: Premium finish for corrosive environments

#### Doors

- Heavy-duty doors on an isolated door frame minimize heat loss. Wire core gaskets create a tight seal for efficient heating.
- Explosion venting latches
- Standard: Bi-parting swing doors
- Optional:
  - Vertical lift guillotine door
  - Door windows

#### Floor

- Standard: 12 ga. plate floor
- Optional:
  - 12 ga. plate floor with (1) pair inverted angle track
  - 12 ga. plate floor with (1) pair 6" wide wheel guides
  - Insulated (100 p.s.f. max.)
  - Insulated with (1) pair inverted angle track
  - Insulated with (1) pair 6" wide wheel guides
  - No floor

#### Input Voltage

- Standard 480/3/60
- Please consult factory for other available options.

#### Controls

- Single set-point temperature controller and redundant high-limit controller
- NEMA 12 enclosure with full voltage lockable disconnect switch
- Circulation fan(s) include air proving circuits that are electrically interlocked with the heating circuit.
- Controls are wired to NFPA 70 and 79 electrical standards, and meet the requirements of NFPA 86, Class B ovens.
- Optional:
  - Door Switch
  - Batch Timer
  - Ramp/ Soak controller
  - Data logger/ chart recorder
  - Zero speed switch for fans
  - Composite curing controls

#### Quality Assurance

- Each unit comes complete with a (1) year warranty and is fully assembled, wired, and tested prior to shipment.
- Unit manufactured under ISO 9001 Quality Certified System.



# Industrial Batch Ovens

Model: SWR06FD

Model (NFPA Class B)	Overall Dimensions			Door Swing Radius	Workspace Dimensions			Workspace Volume (cubic ft.)	Burner (BTU/ Hr)	Circulating Fan (CFM)	Motor (HP)	Air Changes per Minute	Exhaust Fan Capacity (CFM)	Exhaust Motor (HP)	Solvents per Batch (Gals.)	Ships Fully Assembled
	"W	"D	"H		"W	"D	"H									
SWR06FD-48-48-60	82	107	124	24"	48	48	60	80	200,000	1,700	1	21.25	250	1/4	0	Yes
SWR06FD-48-48-72	81	106	135	24"	48	48	72	96	200,000	2,000	1.5	20.83	250	1/4	0	Yes
SWR06FD-48-48-96	83	106	159	24"	48	48	96	128	200,000	2,500	2	19.53	250	1/4	0	No
SWR06FD-48-72-72	83	134	135	24"	48	72	72	144	200,000	3,000	2	20.83	250	1/4	0	Yes
SWR06FD-48-72-96	85	140	159	24"	48	72	96	192	200,000	4,000	3	20.83	250	1/4	0	No
SWR06FD-48-96-72	85	164	135	24"	48	96	72	192	200,000	4,000	3	20.83	250	1/4	0	Yes
SWR06FD-48-96-96	89	168	159	24"	48	96	96	256	400,000	5,000	3	19.53	250	1/4	0	No
SWR06FD-60-60-60	95	118	123	30"	60	60	60	125	200,000	2,500	2	20.00	250	1/4	0	Yes
SWR06FD-60-60-72	95	122	135	30"	60	60	72	150	200,000	3,000	2	20.00	250	1/4	0	Yes
SWR06FD-60-60-96	97	128	159	30"	60	60	96	200	400,000	4,000	3	20.00	250	1/4	0	No
SWR06FD-60-72-72	97	134	135	30"	60	72	72	180	200,000	3,500	3	19.44	250	1/4	0	Yes
SWR06FD-60-72-96	99	144	159	30"	60	72	96	240	400,000	4,500	3	18.75	250	1/4	0	No
SWR06FD-60-96-96	103	174	159	30"	60	96	96	320	400,000	6,000	3	18.75	250	1/4	0	No
SWR06FD-72-72-72	109	140	135	36"	72	72	72	216	400,000	4,000	3	18.52	250	1/4	0	Yes
SWR06FD-72-72-96	113	150	159	36"	72	72	96	288	400,000	5,500	3	19.09	250	1/4	0	No
SWR06FD-72-96-96	121	174	159	36"	72	96	96	384	400,000	8,000	5	20.83	250	1/4	0	No
SWR06FD-72-120-96	125	198	159	36"	72	120	96	480	400,000	9,000	7.5	18.75	250	1/4	0	No
SWR06FD-84-84-84	129	162	147	42"	84	84	84	343	400,000	7,000	5	20.41	250	1/4	0	No
SWR06FD-84-96-84	133	174	147	42"	84	96	84	392	400,000	8,000	5	20.41	250	1/4	0	No
SWR06FD-84-120-84	137	205	147	42"	84	120	84	490	700,000	10,000	7.5	20.41	500	1	0	No
SWR06FD-84-120-96	141	210	159	42"	84	120	96	560	700,000	12,000	7.5	21.43	500	1	0	No
SWR06FD-96-96-96	149	181	159	48"	96	96	96	512	700,000	10,000	7.5	19.53	500	1	0	No
SWR06FD-96-120-96	153	210	159	48"	96	120	96	640	700,000	12,000	7.5	18.75	500	1	0	No
SWR06FD-96-144-96	161	243	159	48"	96	144	96	768	700,000	16,000	10	20.83	500	1	0	No
SWR06FD-96-168-96	167	267	159	48"	96	168	96	896	700,000	18,000	15	20.08	500	1	0	No
SWR06FD-120-120-96	185	219	159	60"	120	120	96	800	700,000	16,000	10	20.00	500	1	0	No
SWR06FD-120-120-120	193	224	183	60"	120	120	120	1,000	700,000	20,000	15	20.00	500	1	0	No
SWR06FD-120-144-96	191	243	159	60"	120	144	96	960	700,000	18,000	15	18.75	500	1	0	No
SWR06FD-120-144-120	197	218	183	60"	120	144	120	1,200	1,000,000	24,000	15	20.00	750	1	0	No
SWR06FD-120-168-96	193	242	159	60"	120	168	96	1,120	1,000,000	22,000	15	19.64	750	1	0	No
SWR06FD-120-168-120	203	242	183	60"	120	168	120	1,400	1,000,000	26,000	15	18.57	750	1	0	No

**NOTE: Sizes are approximate. LEWCO, Inc. reserves the right to change specifications without notice.**



# Industrial Batch Ovens

Model: SWR06FD

Model (NFPA Class A)	Overall Dimensions			Door Swing Radius	Workspace Dimensions			Workspace Volume (cubic ft.)	Burner (BTU/ Hr)	Circulating Fan (CFM)	Motor (HP)	Air Changes per Minute	Exhaust Fan Capacity (CFM)	Exhaust Motor (HP)	Solvents per Batch (Gals.)	Ships Fully Assembled
	"W	"D	"H		"W	"D	"H									
SWR06FD-48-48-60	82	107	124	24"	48	48	60	80	200,000	1,700	1	21.25	250	1/4	0.04	Yes
SWR06FD-48-48-72	81	106	135	24"	48	48	72	96	200,000	2,000	1.5	20.83	250	1/4	0.04	Yes
SWR06FD-48-48-96	83	106	159	24"	48	48	96	128	200,000	2,500	2	19.53	250	1/4	0.04	No
SWR06FD-48-72-72	83	134	135	24"	48	72	72	144	200,000	3,000	2	20.83	250	1/4	0.04	Yes
SWR06FD-48-72-96	85	140	159	24"	48	72	96	192	200,000	4,000	3	20.83	250	1/4	0.04	No
SWR06FD-48-96-72	85	164	135	24"	48	96	72	192	200,000	4,000	3	20.83	250	1/4	0.04	Yes
SWR06FD-48-96-96	89	168	159	24"	48	96	96	256	400,000	5,000	3	19.53	500	1	0.04	No
SWR06FD-60-60-60	95	118	123	30"	60	60	60	125	200,000	2,500	2	20.00	250	1/4	0.04	Yes
SWR06FD-60-60-72	95	122	135	30"	60	60	72	150	200,000	3,000	2	20.00	250	1/4	0.04	Yes
SWR06FD-60-60-96	97	128	159	30"	60	60	96	200	400,000	4,000	3	20.00	500	1	0.04	No
SWR06FD-60-72-72	97	134	135	30"	60	72	72	180	200,000	3,500	3	19.44	250	1/4	0.04	Yes
SWR06FD-60-72-96	99	144	159	30"	60	72	96	240	400,000	4,500	3	18.75	500	1	0.04	No
SWR06FD-60-96-96	103	174	159	30"	60	96	96	320	400,000	6,000	3	18.75	500	1	0.07	No
SWR06FD-72-72-72	109	140	135	36"	72	72	72	216	400,000	4,000	3	18.52	500	1	0.04	Yes
SWR06FD-72-72-96	113	150	159	36"	72	72	96	288	400,000	5,500	3	19.09	500	1	0.04	No
SWR06FD-72-96-96	121	174	159	36"	72	96	96	384	400,000	8,000	5	20.83	500	1	0.07	No
SWR06FD-72-120-96	125	198	159	36"	72	120	96	480	400,000	9,000	7.5	18.75	500	1	0.07	No
SWR06FD-84-84-84	129	162	147	42"	84	84	84	343	400,000	7,000	5	20.41	500	1	0.07	No
SWR06FD-84-96-84	133	174	147	42"	84	96	84	392	400,000	8,000	5	20.41	500	1	0.07	No
SWR06FD-84-120-84	137	205	147	42"	84	120	84	490	700,000	10,000	7.5	20.41	750	1	0.18	No
SWR06FD-84-120-96	141	210	159	42"	84	120	96	560	700,000	12,000	7.5	21.43	750	1	0.18	Yes
SWR06FD-96-96-96	149	181	159	48"	96	96	96	512	700,000	10,000	7.5	19.53	750	1	0.18	Yes
SWR06FD-96-120-96	153	210	159	48"	96	120	96	640	700,000	12,000	7.5	18.75	750	1	0.18	Yes
SWR06FD-96-144-96	161	243	159	48"	96	144	96	768	700,000	16,000	10	20.83	750	1	0.18	Yes
SWR06FD-96-168-96	167	267	159	48"	96	168	96	896	700,000	18,000	15	20.08	750	1	0.18	Yes
SWR06FD-120-120-96	185	219	159	60"	120	120	96	800	700,000	16,000	10	20.00	750	1	0.18	Yes
SWR06FD-120-120-120	193	224	183	60"	120	120	120	1,000	700,000	20,000	15	20.00	750	1	0.18	Yes
SWR06FD-120-144-96	191	243	159	60"	120	144	96	960	700,000	18,000	15	18.75	750	1	0.18	Yes
SWR06FD-120-144-120	197	218	183	60"	120	144	120	1,200	1,000,000	24,000	15	20.00	1,000	1 1/2	0.18	Yes
SWR06FD-120-168-96	193	242	159	60"	120	168	96	1,120	1,000,000	22,000	15	19.64	1,000	1 1/2	0.18	Yes
SWR06FD-120-168-120	203	242	183	60"	120	168	120	1,400	1,000,000	26,000	15	18.57	1,500	2	0.37	Yes

**NOTE: Sizes are approximate. LEWCO, Inc. reserves the right to change specifications without notice.**

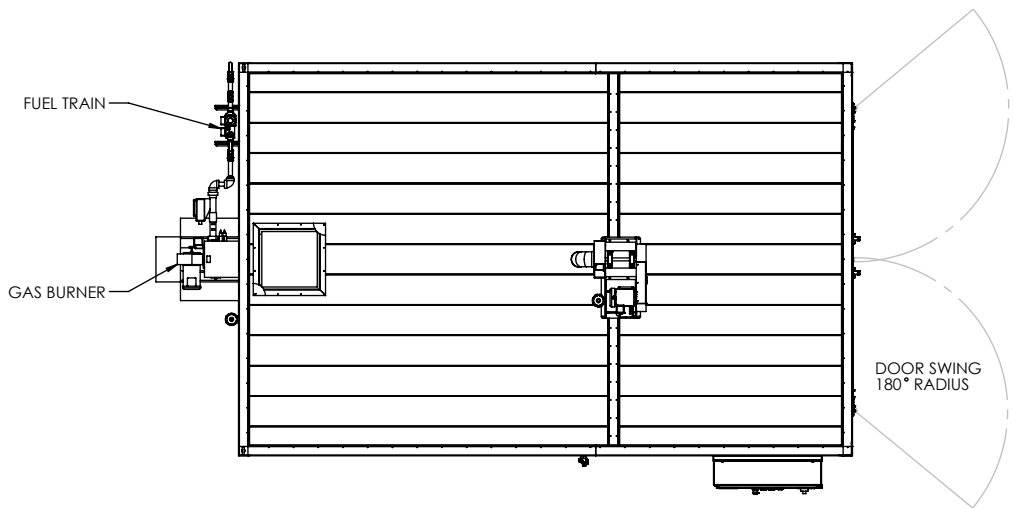

PLAN VIEW

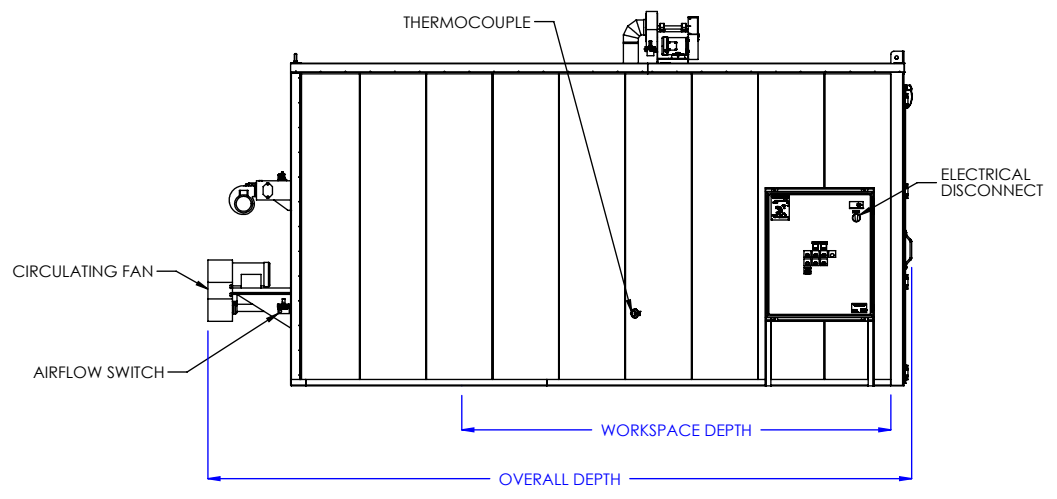

LEFT SIDE ELEVATION

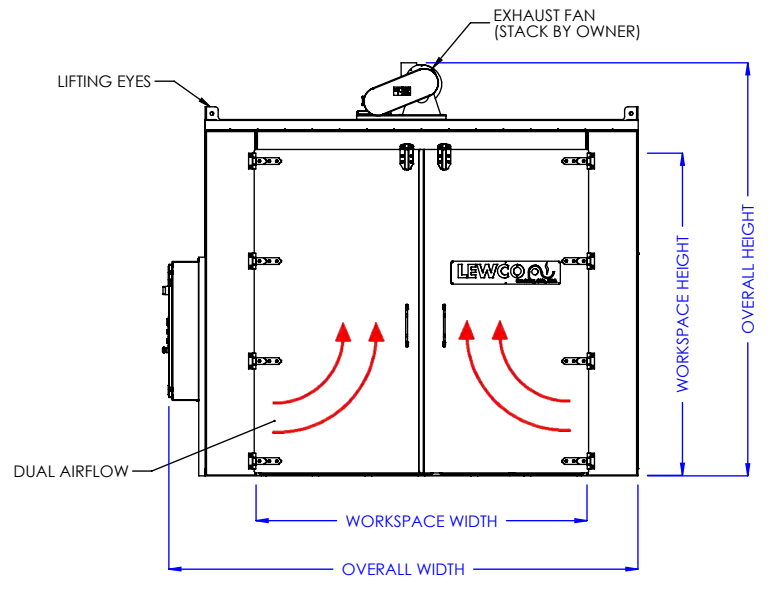

FRONT ELEVATION

MODEL: SWR06FD

DESCRIPTION: NORMAL DUTY WALK-IN OVEN, REAR MOUNT HEATER, 650° F, FUEL-FIRED, DUAL AIRFLOW

**WARNING:** OVENS PROCESSING FLAMMABLE VOLATILES OR COMBUSTIBLE MATERIALS ARE CLASSIFIED BY NFPA 86 AS "CLASS A" OVENS AND REQUIRE SPECIFIC SAFETY FEATURES. KNOW THE PROPERTIES OF THE MATERIALS BEING HEATED. EXPLOSION OR FIRE MAY RESULT FROM MISAPPLICATION.

LEWCO, INC. IS COMMITTED TO CONTINUOUS IMPROVEMENT AND RESERVES THE RIGHT TO CHANGE DESIGNS AND SPECIFICATIONS WITHOUT NOTICE.

THIS DRAWING MUST NOT BE COPIED, REPRODUCED OR USED FOR ANY PURPOSE WITHOUT THE WRITTEN CONSENT OF LEWCO, INC. ALL RIGHTS RESERVED.

DATE:	10/9/2017
REV.	001
PAGE:	1 of 1

