



Model: EWT03FH

Enhanced Duty Walk-In Oven

LEWCO Enhanced-Duty Batch Ovens are designed for critical applications, such as those in the advanced materials and aerospace industries. These models offer all of the same construction features as the Normal-Duty ovens; however the performance is "enhanced" by adding additional heat capacity and larger circulation fans. Enhanced-Duty ovens also guarantee a temperature uniformity of at least +/- 10°F. The EWT series features a top-mounted heater box, which creates a smaller footprint and permits pass-through processing with optional rear doors. Each unit is fully assembled, wired, and tested prior to shipment. All LEWCO ovens are manufactured to meet the requirements of NFPA 86.

Operating Temperature

- 200°F - 350°F (93°C -177°C)

Heating Source & Capacity

- Direct fired natural gas, modulating burner with direct coupled, digital actuated control valve provides visual indication of valve position.
- High turndown ratio allows rapid heat-up and tight temperature control
- Low CO and NOX emissions
- F.M. compliant fuel train

Airflow Pattern

- Horizontal Airflow: Hot air is supplied from one of the side wall and pulled across horizontally to the opposite side wall.

General Construction

- 16 ga. aluminized steel interior
- 18 ga. cold rolled steel exterior
- Heat loss is minimized by a unique wall design featuring a welded inner shell and a completely isolated outer frame and covers.

Finish

- Blue or gray alkyd enamel
- Optional: Premium finish for corrosive environments

Doors

- Heavy-duty doors on an isolated door frame minimize heat loss. Wire core gaskets create a tight seal for efficient heating.
- Explosion venting latches
- Standard: Bi-parting swing doors
- Optional:
 - Vertical lift guillotine door
 - Door windows

Floor

- Standard: 12 ga. plate floor
- Optional:
 - 12 ga. plate floor with (1) pair inverted angle track
 - 12 ga. plate floor with (1) pair 6" wide wheel guides
 - Insulated (100 p.s.f. max.)
 - Insulated with (1) pair inverted angle track
 - Insulated with (1) pair 6" wide wheel guides
 - No floor

Input Voltage

- Standard 480/3/60
- Please consult factory for other available options.

Controls

- Single set-point temperature controller and redundant high-limit controller
- NEMA 12 enclosure with full voltage lockable disconnect switch
- Circulation fan(s) include air proving circuits that are electrically interlocked with the heating circuit.
- Controls are wired to NFPA 70 and 79 electrical standards, and meet the requirements of NFPA 86, Class B ovens.
- Optional:
 - Door Switch
 - Batch Timer
 - Ramp/ Soak controller
 - Data logger/ chart recorder
 - Zero speed switch for fans
 - Composite curing controls

Quality Assurance

- Each unit comes complete with a (1) year warranty and is fully assembled, wired, and tested prior to shipment.
- Unit manufactured under ISO 9001 Quality Certified System.



Industrial Batch Ovens

Model: EWT03FH

Model (NFPA Class B)	Overall Dimensions			Door Swing Radius	Workspace Dimensions			Workspace Volume (cubic ft.)	Burner (BTU/ Hr)	Circulating Fan(s) (CFM)	Motor(s) (HP)	Air Changes per Minute	Exhaust Fan Capacity (CFM)	Exhaust Motor (HP)	Solvents per Batch (Gals.)	Ships Fully Assembled
	"W	"D	"H		"W	"D	"H									
EWT03FH-48-48-60 *	78	60	174	24"	48	48	60	80	200,000	3	1	43.75	100	1/4	0	No
EWT03FH-48-48-72	80	60	186	24"	48	48	72	96	200,000	3	1 1/2	41.67	100	1/4	0	No
EWT03FH-48-48-96	82	60	210	24"	48	48	96	128	200,000	3	2	42.97	100	1/4	0	No
EWT03FH-48-72-72	82	84	187	24"	48	72	72	144	200,000	3	2	41.67	100	1/4	0	No
EWT03FH-48-72-96	84	84	214	24"	48	72	96	192	200,000	5	3	41.67	100	1/4	0	No
EWT03FH-48-96-72	84	108	190	24"	48	96	72	192	200,000	5	3	41.67	100	1/4	0	No
EWT03FH-48-96-96	88	108	218	24"	48	96	96	256	200,000	7 1/2	3	46.88	100	1/4	0	No
EWT03FH-60-60-60 *	94	72	174	30"	60	60	60	125	200,000	3	2	40.00	100	1/4	0	No
EWT03FH-60-60-72	94	72	187	30"	60	60	72	150	200,000	3	2	40.00	100	1/4	0	No
EWT03FH-60-60-96	96	72	214	30"	60	60	96	200	200,000	5	3	40.00	100	1/4	0	No
EWT03FH-60-72-72	96	84	187	30"	60	72	72	180	200,000	5	3	44.44	100	1/4	0	No
EWT03FH-60-72-96	98	84	218	30"	60	72	96	240	200,000	7 1/2	3	41.67	100	1/4	0	No
EWT03FH-60-96-96	102	108	220	30"	60	96	96	320	200,000	10	3	43.75	100	1/4	0	No
EWT03FH-72-72-72	108	84	190	36"	72	72	72	216	200,000	7 1/2	3	41.67	100	1/4	0	No
EWT03FH-72-72-96	112	84	220	36"	72	72	96	288	200,000	7 1/2	3	41.67	100	1/4	0	No
EWT03FH-72-96-96	120	108	220	36"	72	96	96	384	200,000	10	5	41.67	100	1/4	0	No
EWT03FH-72-120-96	124	132	220	36"	72	120	96	480	200,000	15	7 1/2	41.67	100	1/4	0	No

Model (NFPA Class A)	Overall Dimensions			Door Swing Radius	Workspace Dimensions			Workspace Volume (cubic ft.)	Burner (BTU/ Hr)	Circulating Fan(s) (CFM)	Motor(s) (HP)	Air Changes per Minute	Exhaust Fan Capacity (CFM)	Exhaust Motor (HP)	Solvents per Batch (Gals.)	Ships Fully Assembled
	"W	"D	"H		"W	"D	"H									
EWT03FH-48-48-60 *	78	60	174	24"	48	48	60	80	200,000	3,500	3	43.75	250	1/4	0.06	No
EWT03FH-48-48-72	80	60	186	24"	48	48	72	96	200,000	4,000	3	41.67	250	1/4	0.06	No
EWT03FH-48-48-96	82	60	210	24"	48	48	96	128	200,000	5,500	3	42.97	250	1/4	0.06	No
EWT03FH-48-72-72	82	84	187	24"	48	72	72	144	200,000	6,000	3	41.67	250	1/4	0.06	No
EWT03FH-48-72-96	84	84	214	24"	48	72	96	192	200,000	8,000	5	41.67	250	1/4	0.06	No
EWT03FH-48-96-72	84	108	190	24"	48	96	72	192	200,000	8,000	5	41.67	250	1/4	0.06	No
EWT03FH-48-96-96	88	108	218	24"	48	96	96	256	200,000	12,000	7 1/2	46.88	250	1/4	0.06	No
EWT03FH-60-60-60 *	94	72	174	30"	60	60	60	125	200,000	5,000	3	40.00	250	1/4	0.06	No
EWT03FH-60-60-72	94	72	187	30"	60	60	72	150	200,000	6,000	3	40.00	250	1/4	0.06	No
EWT03FH-60-60-96	96	72	214	30"	60	60	96	200	200,000	8,000	5	40.00	250	1/4	0.06	No
EWT03FH-60-72-72	96	84	187	30"	60	72	72	180	200,000	8,000	5	44.44	250	1/4	0.06	No
EWT03FH-60-72-96	98	84	218	30"	60	72	96	240	200,000	10,000	7 1/2	41.67	250	1/4	0.06	No
EWT03FH-60-96-96	102	108	220	30"	60	96	96	320	200,000	14,000	10	43.75	250	1/4	0.06	No
EWT03FH-72-72-72	108	84	190	36"	72	72	72	216	200,000	9,000	7 1/2	41.67	250	1/4	0.06	No
EWT03FH-72-72-96	112	84	220	36"	72	72	96	288	200,000	12,000	7 1/2	41.67	250	1/4	0.06	No
EWT03FH-72-96-96	120	108	220	36"	72	96	96	384	200,000	16,000	10	41.67	250	1/4	0.06	No
EWT03FH-72-120-96	124	132	220	36"	72	120	96	480	200,000	20,000	15	41.67	250	1/4	0.06	No

* Indicates Configuration Style #1. Refer to drawings on page 3 of 4

NOTE: Sizes are approximate. LEWCO, Inc. reserves the right to change specifications without notice.

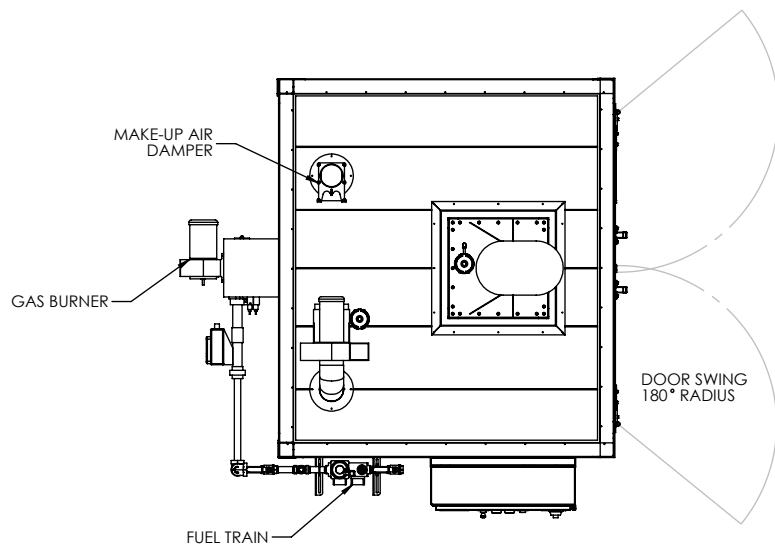

PLAN VIEW

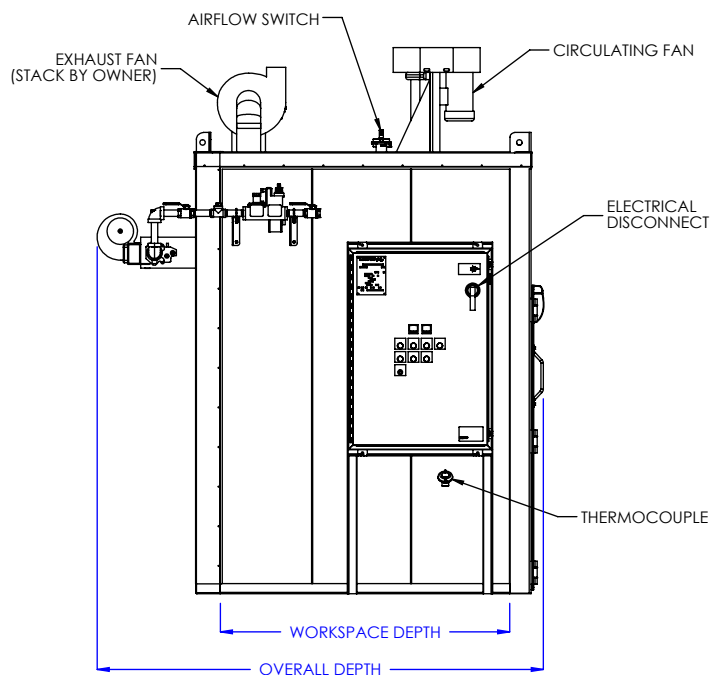

LEFT SIDE ELEVATION

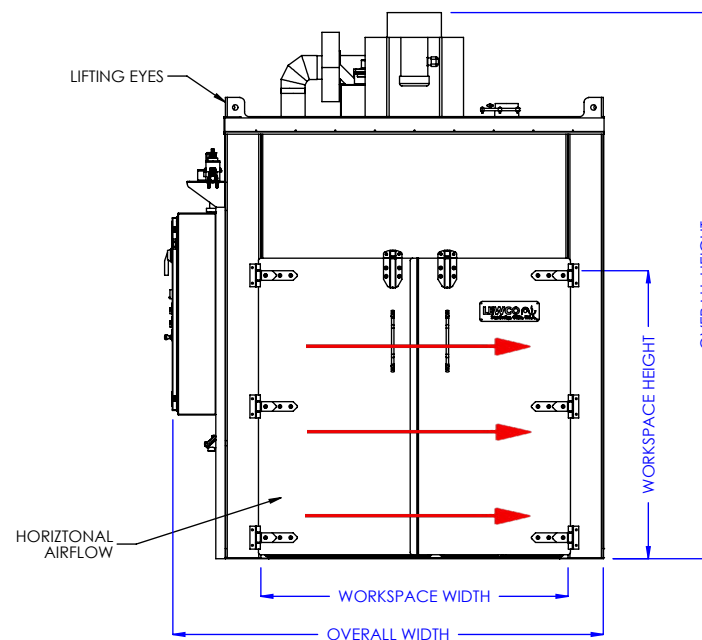

FRONT ELEVATION

MODEL: EWT03FH

DESCRIPTION: ENHANCED DUTY WALK-IN OVEN, TOP MOUNT HEATER, 350°F, FUEL-FIRED, HORIZONTAL AIRFLOW

WARNING: OVENS PROCESSING FLAMMABLE VOLATILES OR COMBUSTIBLE MATERIALS ARE CLASSIFIED BY NFPA 86 AS "CLASS A" OVENS AND REQUIRE SPECIFIC SAFETY FEATURES. KNOW THE PROPERTIES OF THE MATERIALS BEING HEATED. EXPLOSION OR FIRE MAY RESULT FROM MISAPPLICATION.

LEWCO, INC. IS COMMITTED TO CONTINUOUS IMPROVEMENT AND RESERVES THE RIGHT TO CHANGE DESIGNS AND SPECIFICATIONS WITHOUT NOTICE.

THIS DRAWING MUST NOT BE COPIED, REPRODUCED OR USED FOR ANY PURPOSE WITHOUT THE WRITTEN CONSENT OF LEWCO, INC. ALL RIGHTS RESERVED.

DATE: 10/11/2017

REV. 001

PAGE: 3 of 4



706 LANE ST. SANDUSKY, OH 44870, U.S.A.

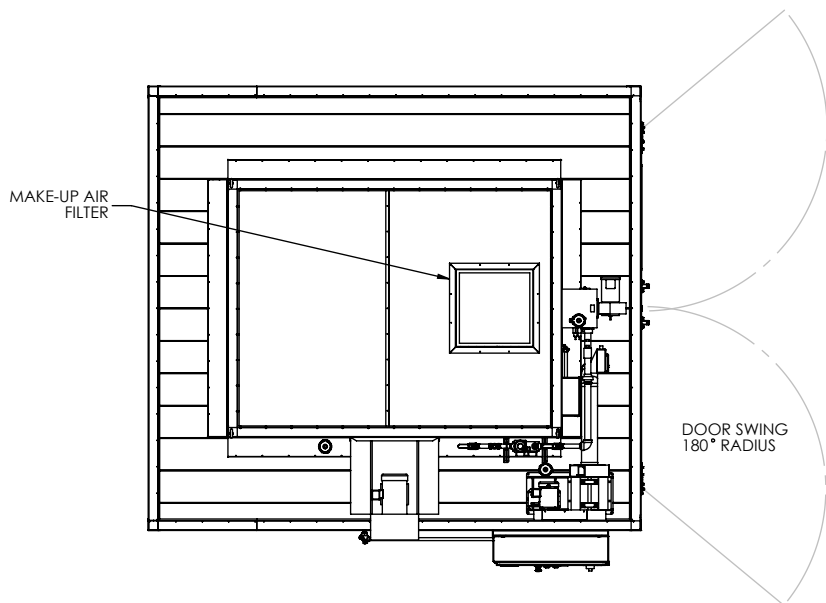

PLAN VIEW

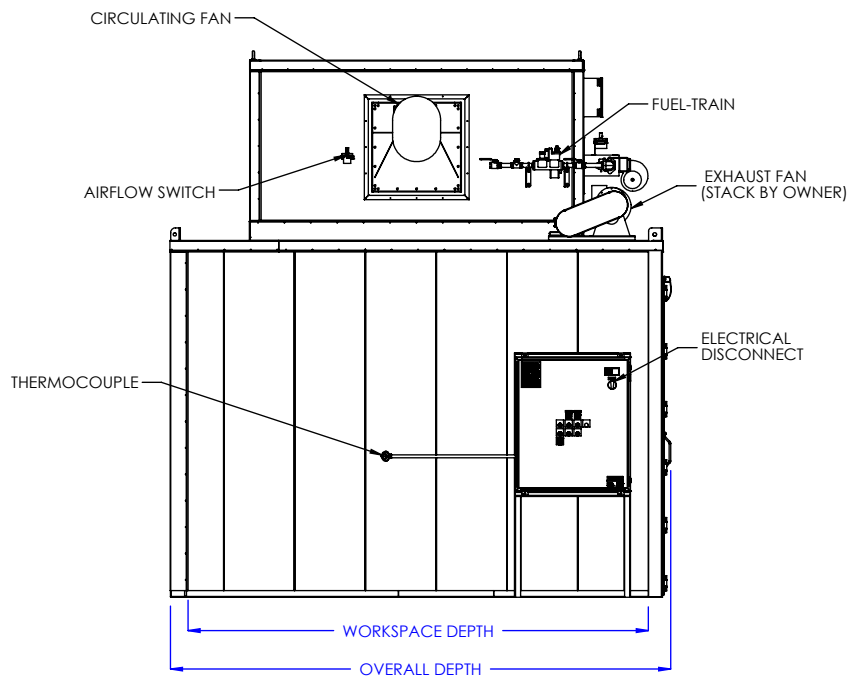

LEFT SIDE ELEVATION

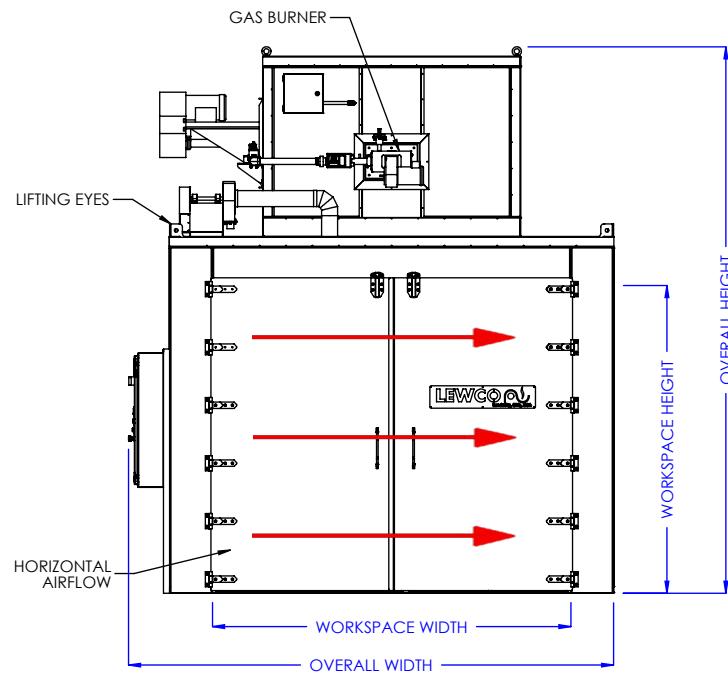

FRONT ELEVATION

MODEL: EWT03FH

DESCRIPTION: ENHANCED DUTY WALK-IN OVEN, TOP MOUNT HEATER, 350°F, FUEL-FIRED, HORIZONTAL AIRFLOW

WARNING: OVENS PROCESSING FLAMMABLE VOLATILES OR COMBUSTIBLE MATERIALS ARE CLASSIFIED BY NFPA 86 AS "CLASS A" OVENS AND REQUIRE SPECIFIC SAFETY FEATURES. KNOW THE PROPERTIES OF THE MATERIALS BEING HEATED. EXPLOSION OR FIRE MAY RESULT FROM MISAPPLICATION.

LEWCO, INC. IS COMMITTED TO CONTINUOUS IMPROVEMENT AND RESERVES THE RIGHT TO CHANGE DESIGNS AND SPECIFICATIONS WITHOUT NOTICE.

THIS DRAWING MUST NOT BE COPIED, REPRODUCED OR USED FOR ANY PURPOSE WITHOUT THE WRITTEN CONSENT OF LEWCO, INC. ALL RIGHTS RESERVED.

DATE: 7/6/2017

REV. 001

PAGE: 4 of 4



706 LANE ST. SANDUSKY, OH 44870, U.S.A.