



Model: SWR03FH

Normal Duty Walk-In Oven

LEWCO Normal-Duty Batch Ovens are designed for common applications, such as pre-heating, drying, and baking. These models offer quality and performance at economical prices. Heavy-duty construction and industry standard components yield durable and reliable equipment. The SWR series features a rear-mounted heater box, which is ideal for installations with height restrictions. Each unit is fully assembled, wired, and tested prior to shipment. All LEWCO ovens are manufactured to meet the requirements of NFPA 86.

Operating Temperature

- 200°F - 350°F (93°C -177°C)

Heating Source & Capacity

- Direct fired natural gas, modulating burner with direct coupled, digital actuated control valve provides visual indication of valve position.
- High turndown ratio allows rapid heat-up and tight temperature control
- Low CO and NOX emissions
- F.M. compliant fuel train

Airflow Pattern

- Horizontal Airflow: Hot air is supplied from one side of the wall and pulled across horizontally to the opposite side wall.

General Construction

- 16 ga. aluminized steel interior
- 18 ga. cold rolled steel exterior
- Heat loss is minimized by a unique wall design featuring a welded inner shell and a completely isolated outer frame and covers.

Finish

- Blue or gray alkyd enamel
- Optional: Premium finish for corrosive environments

Doors

- Heavy-duty doors on an isolated door frame minimize heat loss. Wire core gaskets create a tight seal for efficient heating.
- Explosion venting latches
- Standard: Bi-parting swing doors
- Optional:
 - Vertical lift guillotine door
 - Door windows

Floor

- Standard: 12 ga. plate floor
- Optional:
 - 12 ga. plate floor with (1) pair inverted angle track
 - 12 ga. plate floor with (1) pair 6" wide wheel guides
 - Insulated (100 p.s.f. max.)
 - Insulated with (1) pair inverted angle track
 - Insulated with (1) pair 6" wide wheel guides
 - No floor

Input Voltage

- Standard 480/3/60
- Please consult factory for other available options.

Controls

- Single set-point temperature controller and redundant high-limit controller
- NEMA 12 enclosure with full voltage lockable disconnect switch
- Circulation fan(s) include air proving circuits that are electrically interlocked with the heating circuit.
- Controls are wired to NFPA 70 and 79 electrical standards, and meet the requirements of NFPA 86, Class B ovens.
- Optional:
 - Door Switch
 - Batch Timer
 - Ramp/ Soak controller
 - Data logger/ chart recorder
 - Zero speed switch for fans
 - Composite curing controls

Quality Assurance

- Each unit comes complete with a (1) year warranty and is fully assembled, wired, and tested prior to shipment.
- Unit manufactured under ISO 9001 Quality Certified System.



Industrial Batch Ovens

Model: SWR03FH

Model (NFPA Class B)	Overall Dimensions			Door Swing Radius	Workspace Dimensions			Workspace Volume (cubic ft.)	Burner (BTU/ Hr)	Circulating Fan (CFM)	Motor (HP)	Air Changes per Minute	Exhaust Fan Capacity (CFM)	Exhaust Motor (HP)	Solvents per Batch (Gals.)	Ships Fully Assembled
	"W	"D	"H		"W	"D	"H									
SWR03FH-48-48-60	81	106	123	24"	48	48	60	80	200,000	1,000	1	12.50	100	1/4	0	Yes
SWR03FH-48-48-72	83	106	135	24"	48	48	72	96	200,000	1,400	1	14.58	100	1/4	0	Yes
SWR03FH-48-48-96	87	106	159	24"	48	48	96	128	200,000	1,700	1	13.28	100	1/4	0	No
SWR03FH-48-72-72	87	130	135	24"	48	72	72	144	200,000	1,700	1	11.81	100	1/4	0	Yes
SWR03FH-48-72-96	93	130	159	24"	48	72	96	192	200,000	2,500	2	13.02	100	1/4	0	No
SWR03FH-48-96-72	93	154	135	24"	48	96	72	192	200,000	2,500	2	13.02	100	1/4	0	Yes
SWR03FH-48-96-96	95	158	159	24"	48	96	96	256	200,000	3,000	2	11.72	100	1/4	0	No
SWR03FH-60-60-60	95	118	123	30"	60	60	60	125	200,000	1,400	1	11.20	100	1/4	0	Yes
SWR03FH-60-60-72	99	118	135	30"	60	60	72	150	200,000	1,700	1	11.33	100	1/4	0	Yes
SWR03FH-60-60-96	105	118	159	30"	60	60	96	200	200,000	2,500	2	12.50	100	1/4	0	No
SWR03FH-60-72-72	105	130	135	30"	60	72	72	180	200,000	2,500	2	13.88	100	1/4	0	Yes
SWR03FH-60-72-96	107	134	159	30"	60	72	96	240	200,000	3,000	2	12.50	100	1/4	0	No
SWR03FH-60-96-96	111	164	159	30"	60	96	96	320	200,000	4,000	3	12.50	100	1/4	0	No
SWR03FH-72-72-72	117	130	135	36"	72	72	72	216	200,000	2,500	2	11.57	100	1/4	0	Yes
SWR03FH-72-72-96	123	134	159	36"	72	72	96	288	200,000	3,500	3	12.15	100	1/4	0	No
SWR03FH-72-96-96	127	168	159	36"	72	96	96	384	200,000	4,500	3	11.72	100	1/4	0	No
SWR03FH-72-120-96	131	198	159	36"	72	120	96	480	200,000	5,500	3	11.46	100	1/4	0	No

Model (NFPA Class A)	Overall Dimensions			Door Swing Radius	Workspace Dimensions			Workspace Volume (cubic ft.)	Burner (BTU/ Hr)	Circulating Fan (CFM)	Motor (HP)	Air Changes per Minute	Exhaust Fan Capacity (CFM)	Exhaust Motor (HP)	Solvents per Batch (Gals.)	Ships Fully Assembled
	"W	"D	"H		"W	"D	"H									
SWR03FH-48-48-60	81	106	123	24"	48	48	60	80	200,000	1,000	1	12.50	250	1/4	0.06	Yes
SWR03FH-48-48-72	83	106	135	24"	48	48	72	96	200,000	1,400	1	14.58	250	1/4	0.06	Yes
SWR03FH-48-48-96	87	106	159	24"	48	48	96	128	200,000	1,700	1	13.28	250	1/4	0.06	No
SWR03FH-48-72-72	87	130	135	24"	48	72	72	144	200,000	1,700	1	11.81	250	1/4	0.06	Yes
SWR03FH-48-72-96	93	130	159	24"	48	72	96	192	200,000	2,500	2	13.02	250	1/4	0.06	No
SWR03FH-48-96-72	93	154	135	24"	48	96	72	192	200,000	2,500	2	13.02	250	1/4	0.06	Yes
SWR03FH-48-96-96	95	158	159	24"	48	96	96	256	200,000	3,000	2	11.72	250	1/4	0.06	No
SWR03FH-60-60-60	95	118	123	30"	60	60	60	125	200,000	1,400	1	11.20	250	1/4	0.06	Yes
SWR03FH-60-60-72	99	118	135	30"	60	60	72	150	200,000	1,700	1	11.33	250	1/4	0.06	Yes
SWR03FH-60-60-96	105	118	159	30"	60	60	96	200	200,000	2,500	2	12.50	250	1/4	0.06	No
SWR03FH-60-72-72	105	130	135	30"	60	72	72	180	200,000	2,500	2	13.88	250	1/4	0.06	Yes
SWR03FH-60-72-96	107	134	159	30"	60	72	96	240	200,000	3,000	2	12.50	250	1/4	0.06	No
SWR03FH-60-96-96	111	164	159	30"	60	96	96	320	200,000	4,000	3	12.50	250	1/4	0.10	No
SWR03FH-72-72-72	117	130	135	36"	72	72	72	216	200,000	2,500	2	11.57	250	1/4	0.06	Yes
SWR03FH-72-72-96	123	134	159	36"	72	72	96	288	200,000	3,500	3	12.15	250	1/4	0.06	No
SWR03FH-72-96-96	127	168	159	36"	72	96	96	384	200,000	4,500	3	11.72	250	1/4	0.10	No
SWR03FH-72-120-96	131	198	159	36"	72	120	96	480	200,000	5,500	3	11.46	250	1/4	0.10	No

NOTE: Sizes are approximate. LEWCO, Inc. reserves the right to change specifications without notice.

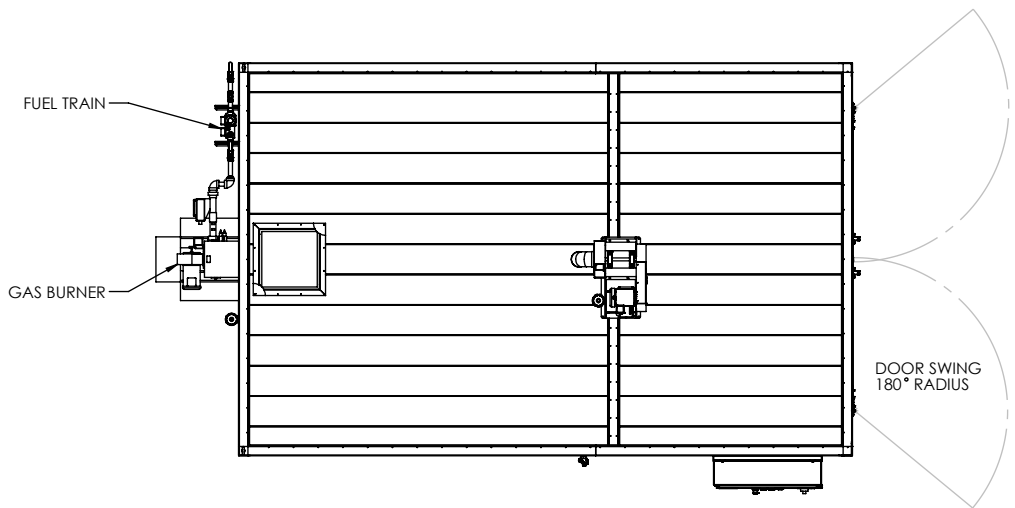

PLAN VIEW

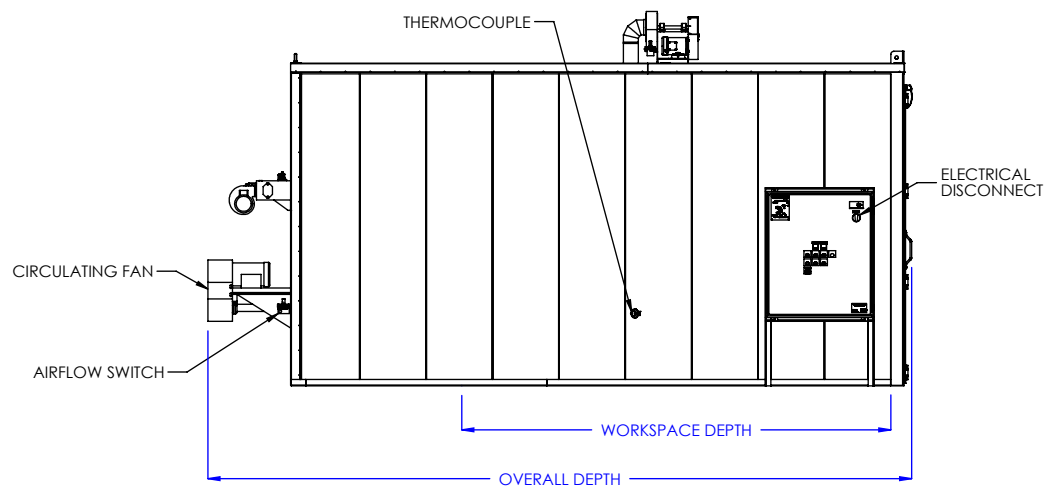

LEFT SIDE ELEVATION

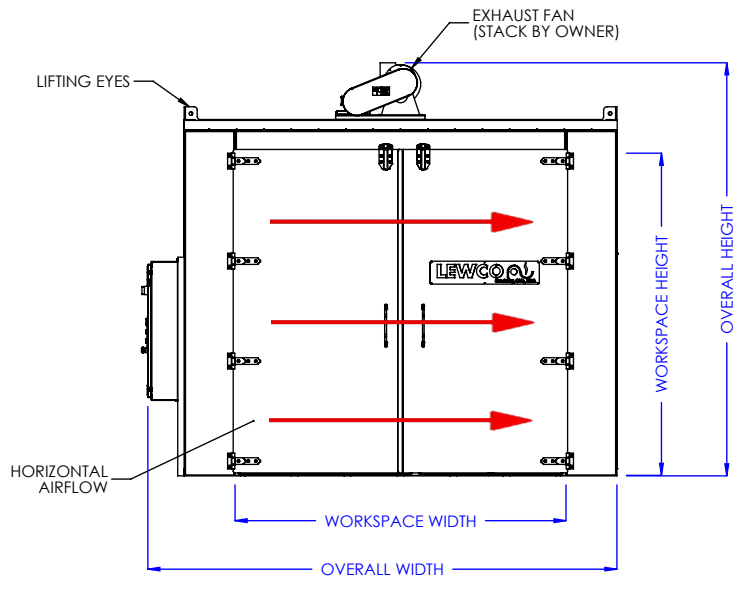

FRONT ELEVATION

MODEL: SWR03FH

DESCRIPTION: NORMAL DUTY WALK-IN OVEN, REAR MOUNT HEATER, 350° F, FUEL-FIRED, HORIZONTAL AIRFLOW

WARNING: OVENS PROCESSING FLAMMABLE VOLATILES OR COMBUSTIBLE MATERIALS ARE CLASSIFIED BY NFPA 86 AS "CLASS A" OVENS AND REQUIRE SPECIFIC SAFETY FEATURES. KNOW THE PROPERTIES OF THE MATERIALS BEING HEATED. EXPLOSION OR FIRE MAY RESULT FROM MISAPPLICATION.

LEWCO, INC. IS COMMITTED TO CONTINUOUS IMPROVEMENT AND RESERVES THE RIGHT TO CHANGE DESIGNS AND SPECIFICATIONS WITHOUT NOTICE.

THIS DRAWING MUST NOT BE COPIED, REPRODUCED OR USED FOR ANY PURPOSE WITHOUT THE WRITTEN CONSENT OF LEWCO, INC. ALL RIGHTS RESERVED.

DATE:	10/9/2017
REV.	001
PAGE:	1 of 1