



Model: SWT03ED

### Normal Duty Walk-In Oven

LEWCO Normal-Duty Batch Ovens are designed for common applications, such as pre-heating, drying, and baking. These models offer quality and performance at economical prices. Heavy-duty construction and industry standard components yield durable and reliable equipment. The SWT series features a top-mounted heater box, which creates a smaller footprint and permits pass-through processing with optional rear doors. Each unit is fully assembled, wired, and tested prior to shipment. All LEWCO ovens are manufactured to meet the requirements of NFPA 86.

#### Operating Temperature

- 150°F - 350°F (66°C -177°C)

#### Heating Source & Capacity

- Electric, low watt density Incoloy® heaters provide years of trouble free service.
- Standard heater bank assemblies are installed in high velocity ductwork to maximize heat transfer.

#### Airflow Pattern

- Dual Airflow: Hot air is supplied from both of the side walls and returned through a top plenum.

#### General Construction

- 16 ga. aluminized steel interior
- 18 ga. cold rolled steel exterior
- Heat loss is minimized by a unique wall design featuring a welded inner shell and a completely isolated outer frame and covers.

#### Finish

- Blue or gray alkyd enamel
- Optional: Premium finish for corrosive environments

#### Doors

- Heavy-duty doors on an isolated door frame minimize heat loss. Wire core gaskets create a tight seal for efficient heating.
- Explosion venting latches
- Standard: Bi-parting swing doors
- Optional:
  - Vertical lift guillotine door
  - Door windows

#### Floor

- Standard: 12 ga. plate floor
- Optional:
  - 12 ga. plate floor with (1) pair inverted angle track
  - 12 ga. plate floor with (1) pair 6" wide wheel guides
  - Insulated (100 p.s.f. max.)
  - Insulated with (1) pair inverted angle track
  - Insulated with (1) pair 6" wide wheel guides
  - No floor

#### Input Voltage

- Standard 480/3/60
- Please consult factory for other available options.

#### Controls

- Single set-point temperature controller and redundant high-limit controller
- NEMA 12 enclosure with full voltage lockable disconnect switch
- Circulation fan(s) include air proving circuits that are electrically interlocked with the heating circuit.
- Controls are wired to NFPA 70 and 79 electrical standards, and meet the requirements of NFPA 86, Class B ovens.
- Optional:
  - Door Switch
  - Batch Timer
  - Ramp/ Soak controller
  - Data logger/ chart recorder
  - Zero speed switch for fans
  - Composite curing controls

#### Quality Assurance

- Each unit comes complete with a (1) year warranty and is fully assembled, wired, and tested prior to shipment.
- Unit manufactured under ISO 9001 Quality Certified System.



# Industrial Batch Ovens

Model: SWT03ED

Model (NFPA Class B)	Overall Dimensions			Door Swing Radius	Workspace Dimensions			Workspace Volume (cubic ft.)	Heater Bank (kW)	Circulating Fan(s) (CFM)	Motor(s) (HP)	Air Changes per Minute	Exhaust Fan Capacity (CFM)	Exhaust Motor (HP)	Solvents per Batch (Gals.)	Ships Fully Assembled
	"W	"D	"H		"W	"D	"H									
SWT03ED-48-48-60	78	59	91	34"	48	48	60	80	36	1,000	1	12.50	N/A	N/A	0	Yes
SWT03ED-48-48-72	78	59	103	34"	48	48	72	96	36	1,400	1	14.58	N/A	N/A	0	Yes
SWT03ED-48-48-96	78	59	127	34"	48	48	96	128	36	1,700	1	13.28	N/A	N/A	0	Yes
SWT03ED-60-60-60	90	71	91	40"	60	60	60	125	36	1,400	1	11.20	N/A	N/A	0	Yes
SWT03ED-60-60-72	90	71	103	40"	60	60	72	150	36	1,700	1	11.33	N/A	N/A	0	Yes
SWT03ED-60-60-96	90	71	127	40"	60	60	96	200	36	2,500	2	12.50	N/A	N/A	0	Yes
SWT03ED-72-72-72	102	83	103	46"	72	72	72	216	36	2,500	2	11.57	N/A	N/A	0	Yes
SWT03ED-72-72-96	102	83	132	46"	72	72	96	288	45	3,500	3	12.15	N/A	N/A	0	Yes
SWT03ED-72-120-96	104	131	145	46"	72	120	96	480	63	5,500	3	11.46	N/A	N/A	0	No
SWT03ED-84-84-84	116	95	134	52"	84	84	84	343	54	4,000	3	11.66	N/A	N/A	0	Yes
SWT03ED-84-96-84	120	107	133	52"	84	96	84	392	54	4,500	3	11.48	N/A	N/A	0	Yes
SWT03ED-84-120-84	122	131	134	52"	84	120	84	490	63	5,500	3	11.22	N/A	N/A	0	Yes
SWT03ED-84-120-96	122	131	151	52"	84	120	96	560	63	7,000	5	12.50	N/A	N/A	0	No
SWT03ED-96-96-96	128	107	146	58"	96	96	96	512	63	6,000	3	11.72	N/A	N/A	0	No
SWT03ED-96-120-96	132	131	145	58"	96	120	96	640	72	8,000	5	12.50	N/A	N/A	0	No
SWT03ED-96-144-96	134	155	146	58"	96	144	96	768	81	9,000	7 1/2	11.72	N/A	N/A	0	No
SWT03ED-96-168-96	134	179	151	58"	96	168	96	896	90	12,000	7 1/2	11.16	N/A	N/A	0	No
SWT03ED-96-192-96	136	203	158	58"	96	192	96	1,024	99	12,000	7 1/2	11.72	N/A	N/A	0	No
SWT03ED-96-240-96	140	251	163	58"	96	240	96	1,280	108	16,000	10	12.50	N/A	N/A	0	No
SWT03ED-96-240-120	142	251	191	58"	96	240	120	1,600	135	18,000	15	11.25	N/A	N/A	0	No
SWT03ED-96-288-96	142	299	167	58"	96	288	96	1,536	135	18,000	15	11.72	N/A	N/A	0	No
SWT03ED-96-288-120	144	299	203	58"	96	288	120	1,920	153	22,000	15	11.46	N/A	N/A	0	No
SWT03ED-96-336-96	144	347	174	58"	96	336	96	1,792	153	22,000	15	11.16	N/A	N/A	0	No
SWT03ED-96-336-120	148	347	205	58"	96	336	120	2,240	171	26,000	15	11.61	N/A	N/A	0	No
SWT03ED-120-120-96	158	131	147	70"	120	120	96	800	81	9,000	7 1/2	11.25	N/A	N/A	0	No
SWT03ED-120-120-120	160	131	182	70"	120	120	120	1,000	90	12,000	7 1/2	12.00	N/A	N/A	0	No
SWT03ED-120-144-96	160	155	156	70"	120	144	96	960	90	12,000	7 1/2	12.5	N/A	N/A	0	No
SWT03ED-120-144-120	162	155	182	70"	120	144	120	1,200	99	14,000	10	11.67	N/A	N/A	0	No
SWT03ED-120-168-96	162	179	158	70"	120	168	96	1,120	99	14,000	10	12.5	N/A	N/A	0	No
SWT03ED-120-168-120	164	179	189	70"	120	168	120	1,400	108	16,000	10	11.43	N/A	N/A	0	No
SWT03ED-120-192-96	164	203	163	70"	120	192	96	1,280	108	16,000	10	12.5	N/A	N/A	0	No
SWT03ED-120-192-120	166	203	189	70"	120	192	120	1,600	135	18,000	15	11.25	N/A	N/A	0	No
SWT03ED-120-240-96	166	251	165	70"	120	240	96	1,600	135	18,000	15	11.25	N/A	N/A	0	No
SWT03ED-120-240-120	168	251	204	70"	120	240	120	2,000	153	24,000	15	11	N/A	N/A	0	No
SWT03ED-120-288-96	168	299	178	70"	120	288	96	1,920	153	22,000	15	11.46	N/A	N/A	0	No
SWT03ED-120-288-120	172	299	212	70"	120	288	120	2,400	171	28,000	15	11.67	N/A	N/A	0	No
SWT03ED-120-336-96	172	347	181	70"	120	336	96	2,240	171	26,000	15	11.61	N/A	N/A	0	No
SWT03ED-120-336-120	172	347	212	70"	120	336	120	2,800	189	16,000(x2)	10(x2)	11.42	N/A	N/A	0	No

NOTE: Sizes are approximate. LEWCO, Inc. reserves the right to change specifications without notice.



# Industrial Batch Ovens

Model: SWT03ED

Model (NFPA Class A)	Overall Dimensions			Door Swing Radius	Workspace Dimensions			Workspace Volume (cubic ft.)	Heater Bank (kW)	Circulating Fan(s) (CFM)	Motor(s) (HP)	Air Changes per Minute	Exhaust Fan Capacity (CFM)	Exhaust Motor (HP)	Solvents per Batch (Gals.)	Ships Fully Assembled
	"W	"D	"H		"W	"D	"H									
SWT03ED-48-48-60	78	59	91	34"	48	48	60	80	36	1,000	1	12.50	62	1/4	0.06	Yes
SWT03ED-48-48-72	78	59	103	34"	48	48	72	96	36	1,400	1	14.58	62	1/4	0.06	Yes
SWT03ED-48-48-96	78	59	127	34"	48	48	96	128	36	1,700	1	13.28	62	1/4	0.06	Yes
SWT03ED-60-60-60	90	71	91	40"	60	60	60	125	36	1,400	1	11.20	62	1/4	0.06	Yes
SWT03ED-60-60-72	90	71	103	40"	60	60	72	150	36	1,700	1	11.33	62	1/4	0.06	Yes
SWT03ED-60-60-96	90	71	127	40"	60	60	96	200	45	2,500	2	12.50	62	1/4	0.06	Yes
SWT03ED-72-72-72	102	83	103	46"	72	72	72	216	45	2,500	2	11.57	62	1/4	0.06	Yes
SWT03ED-72-72-96	102	83	132	46"	72	72	96	288	54	3,500	3	12.15	62	1/4	0.06	Yes
SWT03ED-72-120-96	104	131	145	46"	72	120	96	480	63	5,500	3	11.46	250	1/4	0.10	No
SWT03ED-84-84-84	116	95	134	52"	84	84	84	343	54	4,000	3	11.66	250	1	0.10	No
SWT03ED-84-96-84	120	107	133	52"	84	96	84	392	63	4,500	3	11.48	250	1	0.10	No
SWT03ED-84-120-84	122	131	134	52"	84	120	84	490	81	5,500	3	11.22	250	1	0.25	No
SWT03ED-84-120-96	122	131	151	52"	84	120	96	560	81	7,000	5	12.50	250	1	0.25	No
SWT03ED-96-96-96	128	107	146	58"	96	96	96	512	81	6,000	3	11.72	250	1/4	0.25	No
SWT03ED-96-120-96	132	131	145	58"	96	120	96	640	90	8,000	5	12.50	250	1/4	0.25	No
SWT03ED-96-144-96	134	155	146	58"	96	144	96	768	90	9,000	7 1/2	11.72	250	1/4	0.25	No
SWT03ED-120-120-96	158	131	147	70"	120	120	96	800	99	9,000	7 1/2	11.25	250	1/4	0.25	No
SWT03ED-120-120-120	160	131	182	70"	120	120	120	1,000	108	12,000	7 1/2	12.00	250	1/4	0.25	No
SWT03ED-120-144-96	160	155	156	70"	120	144	96	960	108	12,000	7 1/2	12.50	250	1/4	0.25	No
SWT03ED-120-144-120	162	155	182	70"	120	144	120	1,200	126	14,000	10	11.67	250	1/4	0.25	No
SWT03ED-120-168-96	162	179	158	70"	120	168	96	1,120	126	14,000	10	12.50	250	1/4	0.25	No
SWT03ED-120-168-120	164	179	189	70"	120	168	120	1,400	153	16,000	10	11.43	750	1	0.51	No
SWT03ED-120-192-96	164	203	163	70"	120	192	96	1,280	144	16,000	10	12.5	750	1	0.51	No
SWT03ED-120-192-120	166	203	189	70"	120	192	120	1,600	180	18,000	15	11.25	1,000	1 1/2	0.77	No
SWT03ED-120-240-96	166	251	165	70"	120	240	96	1,600	180	18,000	15	11.25	1,000	1 1/2	0.77	No
SWT03ED-120-240-120	168	251	204	70"	120	240	120	2,000	198	24,000	15	11	1,000	1 1/2	0.77	No
SWT03ED-120-288-96	168	299	178	70"	120	288	96	1,920	198	22,000	15	11.46	1,000	1 1/2	0.77	No
SWT03ED-120-288-120	172	299	212	70"	120	288	120	2,400	225	28,000	15	11.67	1,000	1 1/2	0.77	No
SWT03ED-120-336-96	172	347	181	70"	120	336	96	2,240	225	26,000	15	11.61	1,000	1 1/2	0.77	No
SWT03ED-120-336-120	172	347	212	70"	120	336	120	2,800	261	16,000(x2)	10(x2)	10.71	1,000	1 1/2	0.77	No

**NOTE: Sizes are approximate. LEWCO, Inc. reserves the right to change specifications without notice.**

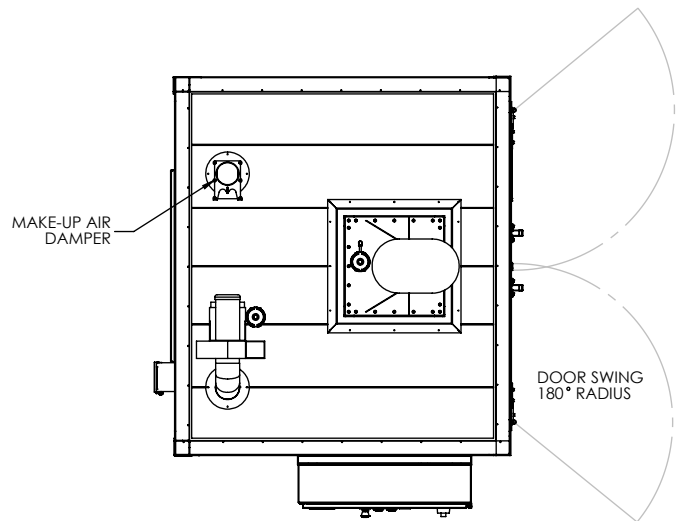

**PLAN VIEW**

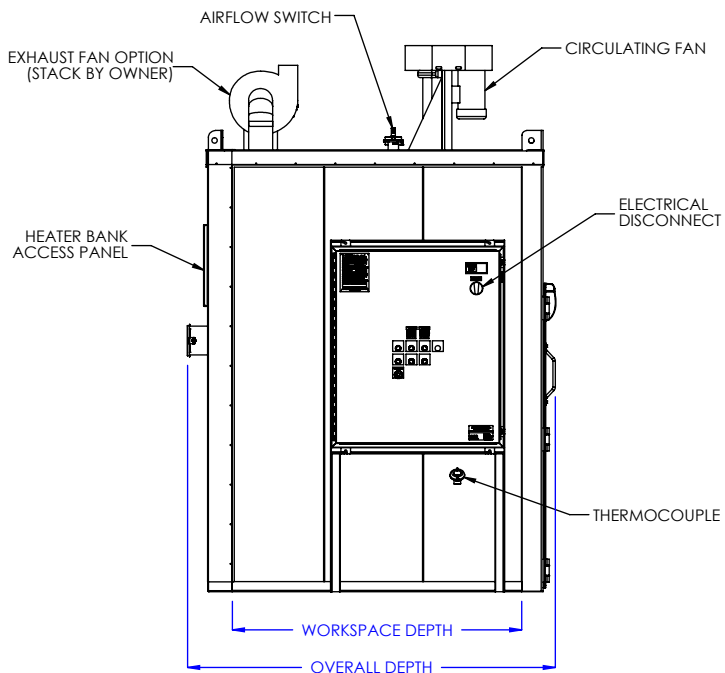

**LEFT SIDE ELEVATION**

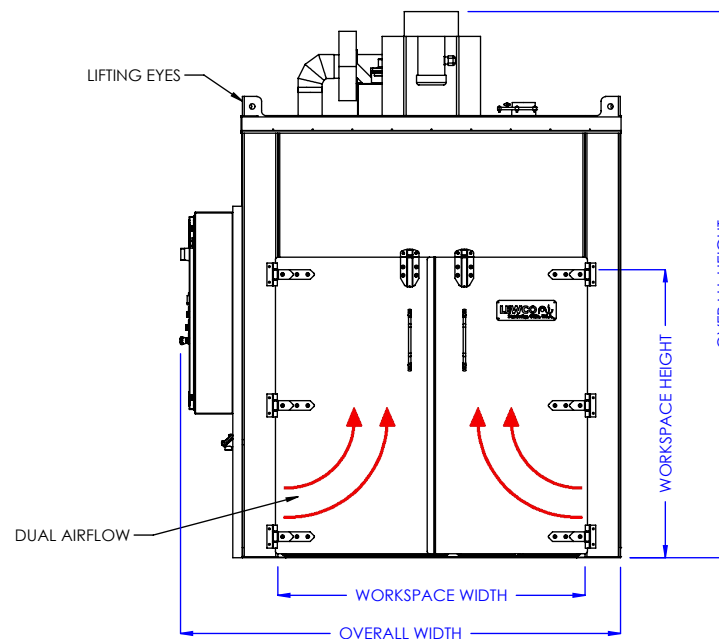

**FRONT ELEVATION**

MODEL: SWT03ED

DESCRIPTION: NORMAL DUTY WALK-IN OVEN, TOP MOUNT HEATER, 350°F, ELECTRIC, DUAL AIRFLOW

**WARNING:** OVENS PROCESSING FLAMMABLE VOLATILES OR COMBUSTIBLE MATERIALS ARE CLASSIFIED BY NFPA 86 AS "CLASS A" OVENS AND REQUIRE SPECIFIC SAFETY FEATURES. KNOW THE PROPERTIES OF THE MATERIALS BEING HEATED. EXPLOSION OR FIRE MAY RESULT FROM MISAPPLICATION.

LEWCO, INC. IS COMMITTED TO CONTINUOUS IMPROVEMENT AND RESERVES THE RIGHT TO CHANGE DESIGNS AND SPECIFICATIONS WITHOUT NOTICE.

THIS DRAWING MUST NOT BE COPIED, REPRODUCED OR USED FOR ANY PURPOSE WITHOUT THE WRITTEN CONSENT OF LEWCO, INC. ALL RIGHTS RESERVED.

DATE: 7/5/2017

REV. 001

PAGE: 4 of 5



706 LANE ST. SANDUSKY, OH 44870, U.S.A.

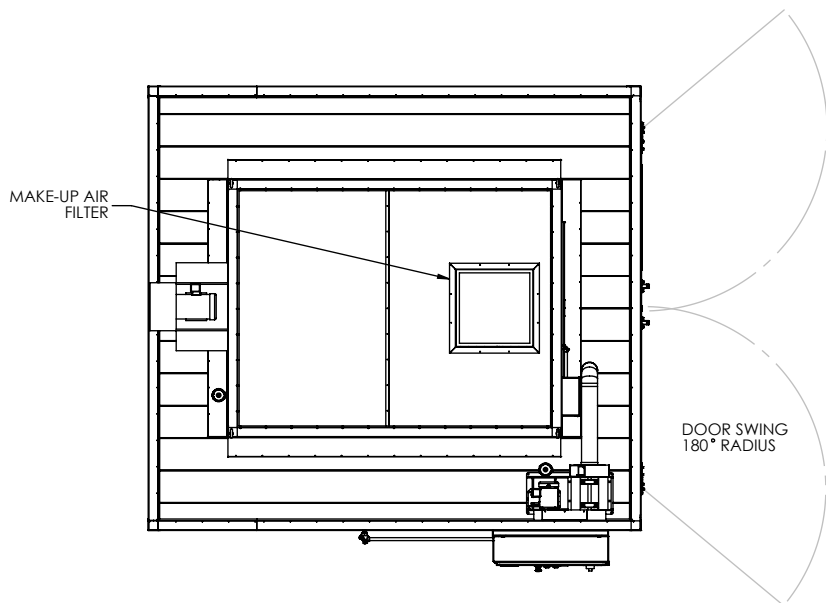

PLAN VIEW

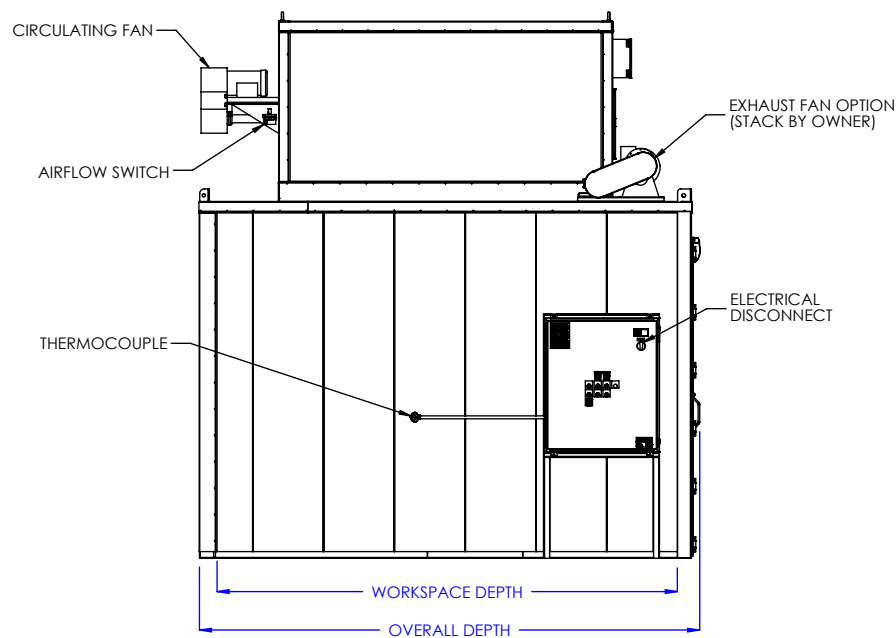

LEFT SIDE ELEVATION

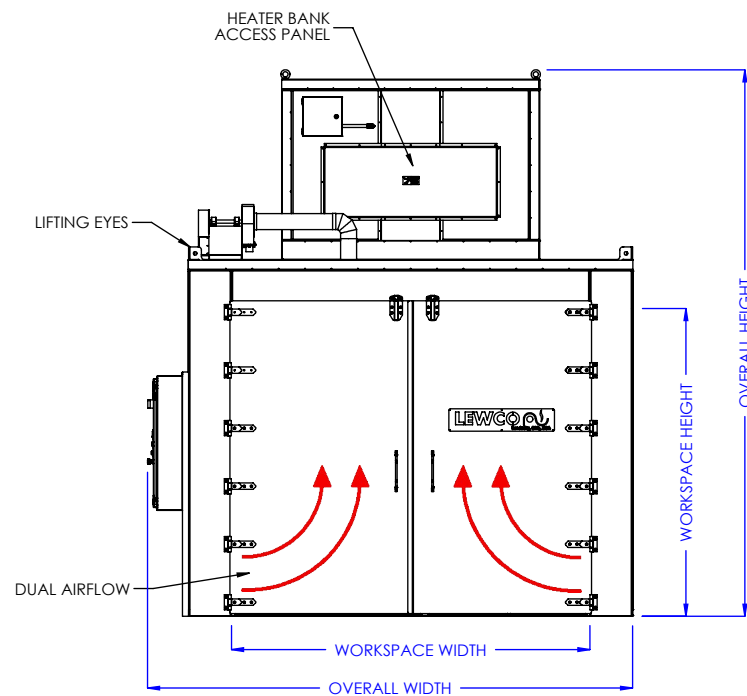

FRONT ELEVATION

MODEL: SWT03ED

DESCRIPTION: NORMAL DUTY WALK-IN OVEN, TOP MOUNT HEATER, 350°F, ELECTRIC, DUAL AIRFLOW

**WARNING:** OVENS PROCESSING FLAMMABLE VOLATILES OR COMBUSTIBLE MATERIALS ARE CLASSIFIED BY NFPA 86 AS "CLASS A" OVENS AND REQUIRE SPECIFIC SAFETY FEATURES. KNOW THE PROPERTIES OF THE MATERIALS BEING HEATED. EXPLOSION OR FIRE MAY RESULT FROM MISAPPLICATION.

LEWCO, INC. IS COMMITTED TO CONTINUOUS IMPROVEMENT AND RESERVES THE RIGHT TO CHANGE DESIGNS AND SPECIFICATIONS WITHOUT NOTICE.

THIS DRAWING MUST NOT BE COPIED, REPRODUCED OR USED FOR ANY PURPOSE WITHOUT THE WRITTEN CONSENT OF LEWCO, INC. ALL RIGHTS RESERVED.

DATE: 7/5/2017

REV. 001

PAGE: 5 of 5