



**Low Profile**

Model: SC04L

### (4) Drum Hot Box, Steam

LEWCO's drum heating product line offers standard cost-effective solutions for melting, viscosity reduction, elevated temperature storage and general industrial heating applications. The Low Profile design allows for convenient loading with a pallet jack or drum dolly. All models feature our signature heavy-duty welded construction and simple, user-friendly controls. Please consult factory for non-standard safety features required for compliance with NFPA 86.

#### Capacity

- (4) 55-gallon drums palletized
- 2,700 lbs. per pallet

#### Operating Temperature

- 125°F - 300°F  
Note: Maximum achievable temperature is dependent on steam pressure.
- Consult factory for applications below 125°F

#### Construction/ Features

- Welded, 1/8" steel shell
- Optional: Stainless steel
- 12 ga. plate steel floor
- Insulation: 3" x 6# mineral wool
- Heavy duty doors with strap hinges, 2-point latch system, and high-temperature silicone rubber gaskets create a tight seal for efficient heating.
- Interior door release for safety

#### Heat Source & Capacity

- Saturated Steam, 20-200 PSIG
- Optional: Hot oil & hot water
- All heat exchangers are welded by A.S.M.E. certified welders and then hydro-tested at 300 PSIG
- Standard: 58 sq. ft.
- Optional: 130 sq. ft.

#### Control Options

- No Controls
- Non-electronic, self-acting temperature controller, limited to 150 psig, available in the following ranges:
  - 125°-212°F, 1/2" valve
  - 158°-300°F, 1/2" valve
- Single set-point temperature controller and redundant high-limit controller.
  - NEMA 12 enclosure with full voltage lockable disconnect switch.
  - Controls are wired to NFPA 70 and 79 electrical standards.
  - Electronic Control Options:
    - Batch Timer
    - Data Logger
    - Door Switch
    - NEMA 7 explosion-proof electrical

#### Finish

- Blue or gray alkyd enamel
- Optional: Premium finish for corrosive environments.

#### Electrical Requirements

- Voltage: 480/3/60
- Disconnect: 30 amps
- Other voltages available
- Depending on options, power may not be required.

#### Shipping & Installation

- Ships completely assembled for easy installation.
- Shipping weight: 1,600 lbs.
- Suitable for indoor use only

#### Additional Options

- Circulating Fan: 330 CFM, TEFC or explosion-proof motor with motor starter
- Steam Trap(s)
- 5" exhaust vent with damper
- UL or CSA Certification
- Custom sizes and features available. Please consult a LEWCO Applications Engineer for more information.

#### Quality Assurance

- Each unit comes complete with a (3) year warranty and is fully assembled, wired, and tested prior to shipment.

\* INDICATES OPTIONAL FEATURE

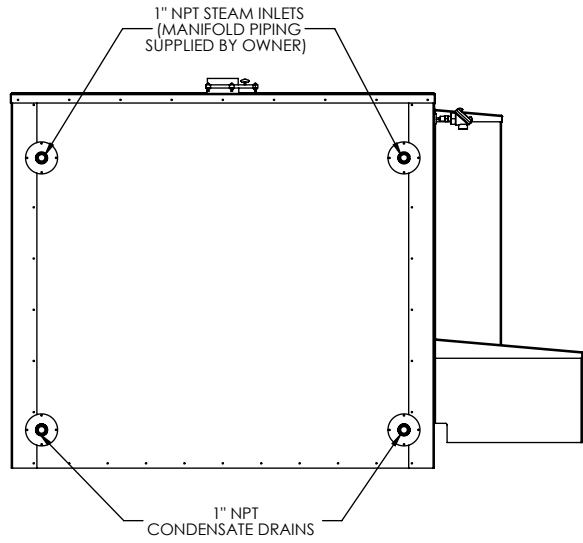

**REAR ELEVATION**

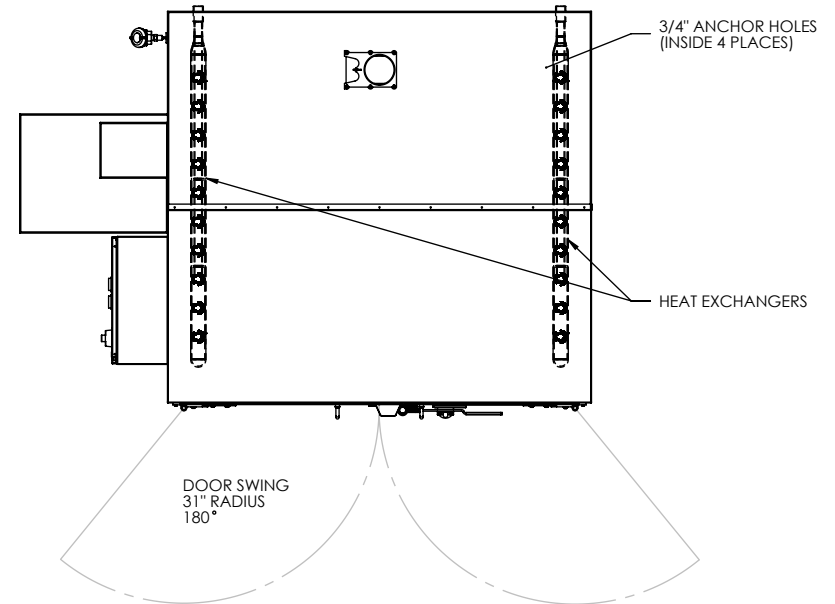

**PLAN VIEW**

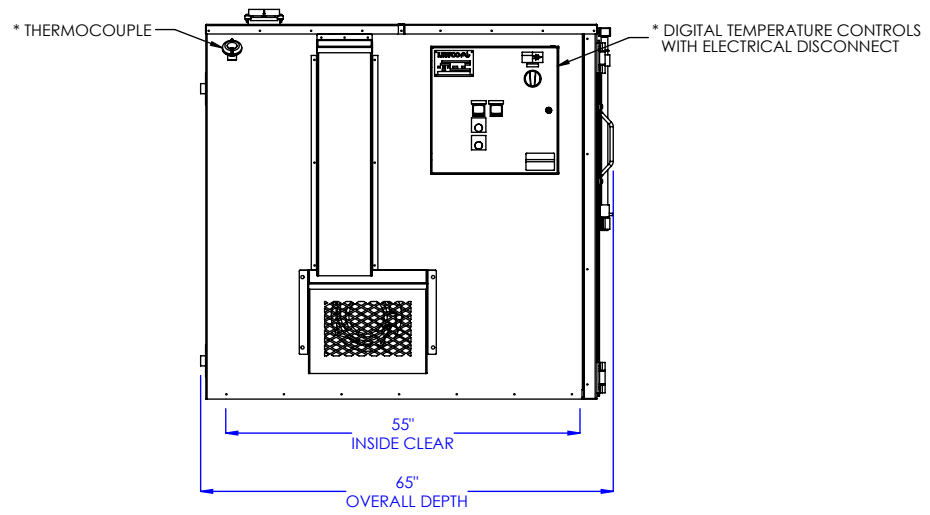

**LEFT SIDE ELEVATION**

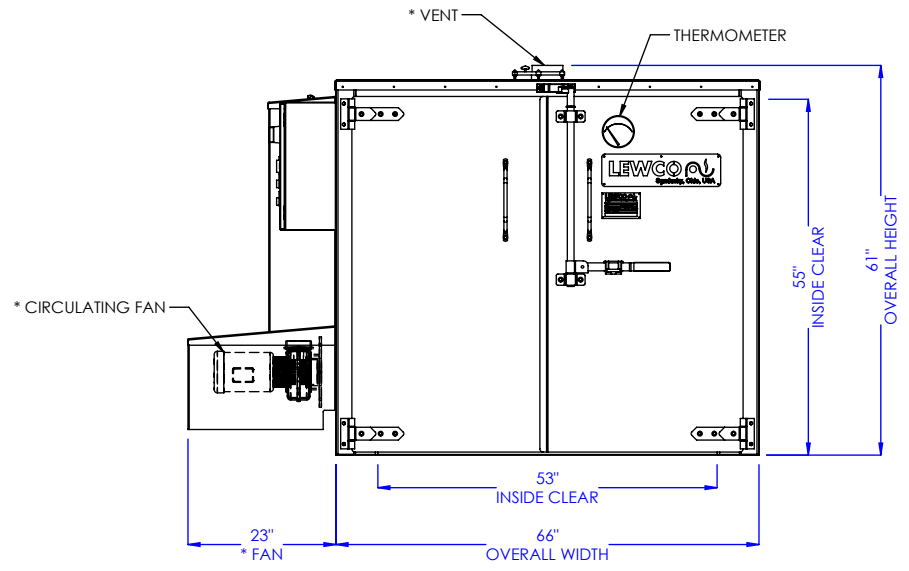

**FRONT ELEVATION**

MODEL: SC04L

DESCRIPTION: STEAM/ THERMAL FLUID HEATING CABINET, 4 DRUM, LOW PROFILE

LEWCO, INC. IS COMMITTED TO CONTINUOUS  
IMPROVEMENT AND RESERVES THE RIGHT TO CHANGE  
DESIGNS AND SPECIFICATIONS WITHOUT NOTICE.

THIS DRAWING MUST NOT BE COPIED, REPRODUCED  
OR USED FOR ANY PURPOSE WITHOUT THE WRITTEN  
CONSENT OF LEWCO, INC. ALL RIGHTS RESERVED.

DATE: 9/22/2016

REV. 001

PAGE: 1 of 1

