



**Low Profile**

Model: SC08L

### (8) Drum Hot Box, Steam

LEWCO's drum heating product line offers standard cost-effective solutions for melting, viscosity reduction, elevated temperature storage and general industrial heating applications. The Low Profile design allows for convenient loading with a pallet jack or drum dolly. All models feature our signature heavy-duty welded construction and simple, user-friendly controls. Please consult factory for non-standard safety features required for compliance with NFPA 86.

#### Capacity

- (8) 55-gallon drums palletized
- 2,700 lbs. per pallet

#### Operating Temperature

- 125°F - 300°F  
Note: Maximum achievable temperature is dependent on steam pressure.
- Consult factory for applications below 125°F

#### Construction/ Features

- Welded, 1/8" steel shell
- Optional: Stainless steel
- 12 ga. plate steel floor
- Insulation: 3" x 6# mineral wool
- Heavy duty doors with strap hinges, 2-point latch system, and high-temperature silicone rubber gaskets create a tight seal for efficient heating.
- Interior door release for safety

#### Heat Source & Capacity

- Saturated Steam, 20-200 PSIG
- Optional: Hot oil & hot water
- All heat exchangers are welded by A.S.M.E. certified welders and then hydro-tested at 300 PSIG
- Standard: 96 sq. ft.
- Optional: 130 sq. ft.

#### Control Options

- No Controls
- Non-electronic, self-acting temperature controller, limited to 150 psig, available in the following ranges:
  - 125°-212°F, 1/2" valve
  - 158°-300°F, 1/2" valve
- Single set-point temperature controller and redundant high-limit controller.
  - NEMA 12 enclosure with full voltage lockable disconnect switch.
  - Controls are wired to NFPA 70 and 79 electrical standards.
  - Electronic Control Options:
    - Batch Timer
    - Data Logger
    - Door Switch
    - NEMA 7 explosion-proof electrical

#### Finish

- Blue or gray alkyd enamel
- Optional: Premium finish for corrosive environments.

#### Electrical Requirements

- Voltage: 480/3/60
- Disconnect: 30 amps
- Other voltages available
- Depending on options, power may not be required.

#### Shipping & Installation

- Ships completely assembled for easy installation.
- Shipping weight: 3,500 lbs.
- Suitable for indoor use only.

#### Additional Options

- Circulating Fan: 1,048 CFM, TEFC or explosion-proof motor with motor starter
- Steam Trap(s)
- 5" exhaust vent with damper
- UL or CSA Certification
- Custom sizes and features available. Please consult a LEWCO Applications Engineer for more information.

#### Quality Assurance

- Each unit comes complete with a (3) year warranty and is fully assembled, wired, and tested prior to shipment.

\* INDICATES OPTIONAL FEATURE

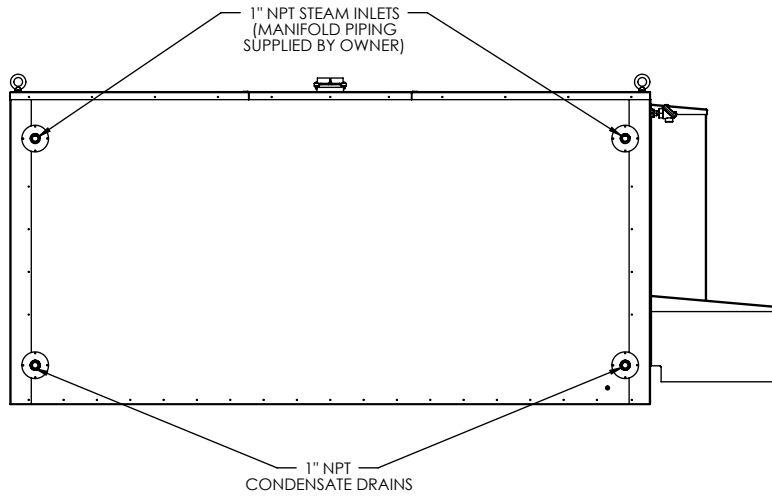

**REAR ELEVATION**

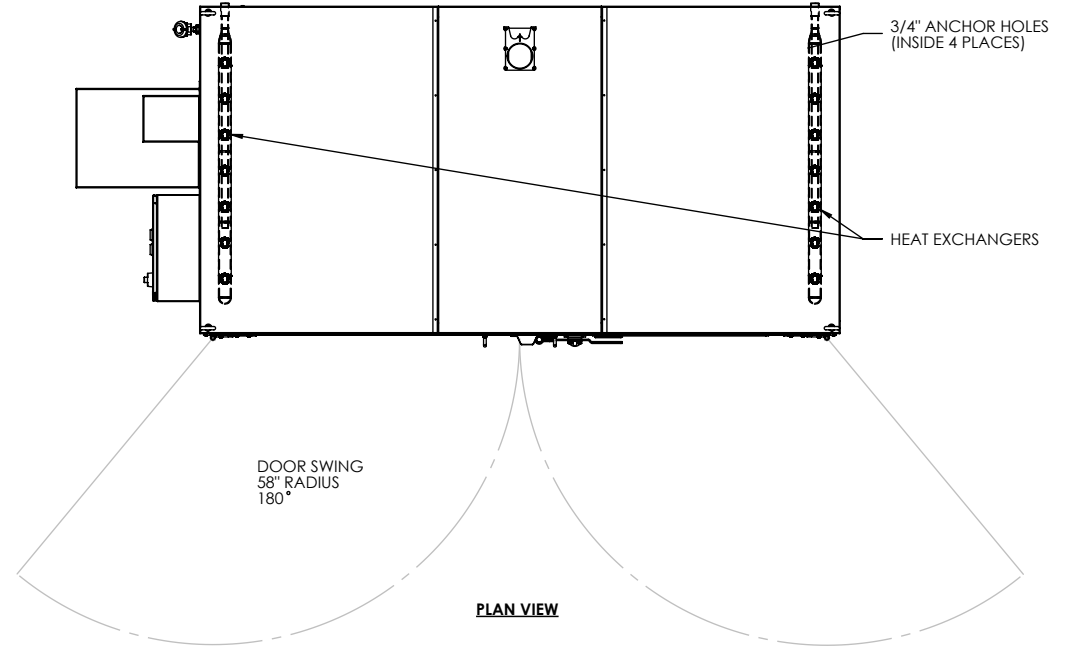

**PLAN VIEW**

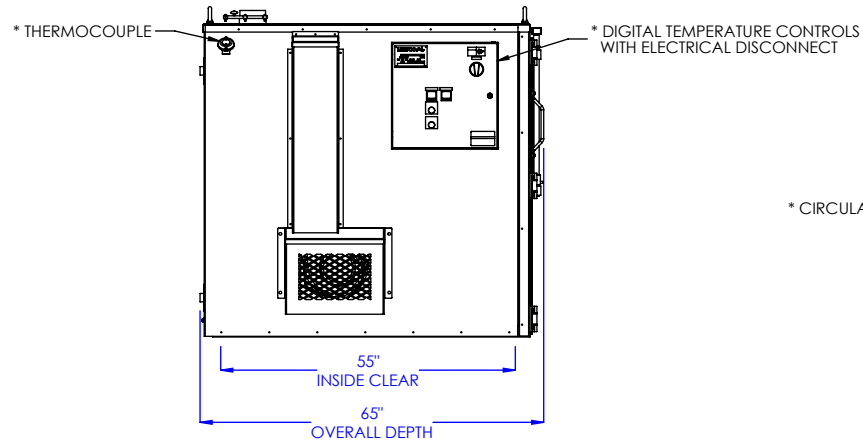

**LEFT SIDE ELEVATION**

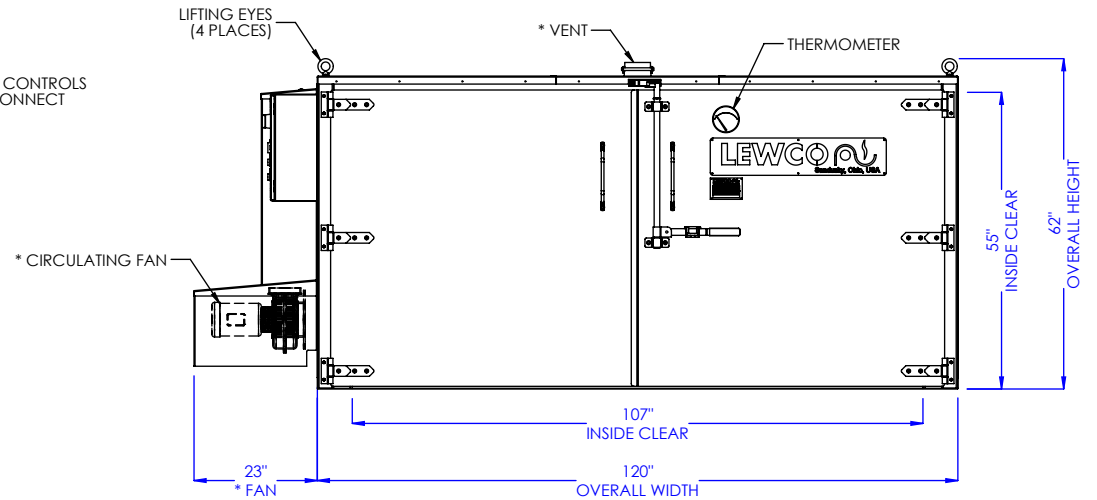

**FRONT ELEVATION**

**MODEL: SC08L**

**DESCRIPTION: STEAM/ THERMAL FLUID HEATING CABINET, 8 DRUM, LOW PROFILE**

LEWCO, INC. IS COMMITTED TO CONTINUOUS  
IMPROVEMENT AND RESERVES THE RIGHT TO CHANGE  
DESIGNS AND SPECIFICATIONS WITHOUT NOTICE.

DATE: 9/22/2016

REV. 001

PAGE: 1 of 1



706 LANE ST. SANDUSKY, OH 44870, U.S.A.

THIS DRAWING MUST NOT BE COPIED, REPRODUCED  
OR USED FOR ANY PURPOSE WITHOUT THE WRITTEN  
CONSENT OF LEWCO, INC. ALL RIGHTS RESERVED.