



Model: SCB05EH Cabinet Oven

LEWCO SCB Series Ovens feature bottom-mounted heater boxes, thereby elevating the oven workspace to approximately 30” for easy loading and unloading. Standard cabinet ovens are offered with electric heat and horizontal airflow. Various shelving configurations available, please consult factory. Heavy-duty construction and industry standard components yield durable and reliable equipment. Each unit is fully assembled, wired, and tested prior to shipment. All LEWCO ovens are manufactured to meet the requirements of NFPA 86.

Operating Temperature

- 150°F - 500°F (66°C - 260°C)

Heat Source & Capacity

- Electric, low watt density Incoloy® heaters provide years of trouble free service.
- Standard heater bank assemblies are installed in high velocity ductwork to maximize heat transfer.

Airflow Pattern

- Horizontal Airflow: Hot air is supplied from one side wall and pulled across horizontally to the opposite side wall. This airflow is best for parts being heated on shelves.

Finish

- Standard: Blue or gray alkyd oil base paint
- Optional: Premium finish for corrosive areas

Available Sizes

- The SCB series is offered in (5) standard sizes with workspace dimensions ranging from:
 - Width: 24” - 48”
 - Depth: 24” - 48”
 - Height: 24” - 48”

General Construction

- 16 ga. aluminized steel interior
- 18 ga. cold rolled steel exterior
- Heat loss is minimized by a unique wall design featuring a welded inner shell and a completely isolated outer frame and covers.

Doors

- Heavy-duty door on an isolated door frame minimizes heat loss. Wire core gaskets create a tight seal for efficient heating.
- Explosion venting latches

Input Voltage

- Standard: 480/3/60
- Optional: 208/ 3/60
- Please consult factory for other available options.

Controls

- Standard: Single-point process temperature controller and redundant high-limit controllers housed in a NEMA 12 enclosure with full voltage lockable disconnect.
- Optional:
 - Door switch
 - Batch timer
 - Ramp/ soak controller
 - Data logger/ chart recorder
 - Zero speed switch for fans

Quality Assurance

- Each unit comes complete with a (1) year warranty and is fully assembled, wired, and tested prior to shipment
- Unit manufactured under ISO 9001 Quality Certified System



Cabinet Ovens

Model: SCB05EH

Model (NFPA Class B)	Overall Dimensions			Door Swing Radius	Workspace Dimensions			Workspace Volume (cubic ft.)	Heater Bank (kW)	Circulating Fan (CFM)	Motor (HP)	Air Changes per Minute	Exhaust Fan Capacity (CFM)	Exhaust Motor (HP)	Solvents per Batch (Gals.)	Ships Fully Assembled
	"W	"D	"H		"W	"D	"H									
SCB05EH-24-24-24	64	37	75	30"	24	24	24	8	18	700	1	87.50	N/A	N/A	0	Yes
SCB05EH-24-24-48	64	37	87	30"	24	24	48	16	18	700	1	43.75	N/A	N/A	0	Yes
SCB05EH-36-36-36	76	49	79	42"	36	36	36	27	18	700	1	25.93	N/A	N/A	0	Yes
SCB05EH-36-36-48	76	49	87	42"	36	36	48	36	36	700	1	19.44	N/A	N/A	0	Yes
SCB05EH-48-48-48	88	61	87	54"	48	48	48	64	36	1,000	1	15.63	N/A	N/A	0	Yes

Model (NFPA Class A)	Overall Dimensions			Door Swing Radius	Workspace Dimensions			Workspace Volume (cubic ft.)	Heater Bank (kW)	Circulating Fan (CFM)	Motor (HP)	Air Changes per Minute	Exhaust Fan Capacity (CFM)	Exhaust Motor (HP)	Solvents per Batch (Gals.)	Ships Fully Assembled
	"W	"D	"H		"W	"D	"H									
SCB05EH-24-24-24	64	37	79	30"	24	24	24	8	36	700	1	87.50	62	1/4	0.05	Yes
SCB05EH-24-24-48	64	37	103	30"	24	24	48	16	36	700	1	43.75	62	1/4	0.05	Yes
SCB05EH-36-36-36	76	49	91	42"	36	36	36	27	36	700	1	25.93	62	1/4	0.05	Yes
SCB05EH-36-36-48	76	49	103	42"	36	36	48	36	36	700	1	19.44	62	1/4	0.05	Yes
SCB05EH-48-48-48	88	61	103	54"	48	48	48	64	36	1,000	1	15.63	62	1/4	0.05	Yes

NOTE: Sizes are approximate. LEWCO, Inc. reserves the right to change specifications without notice.

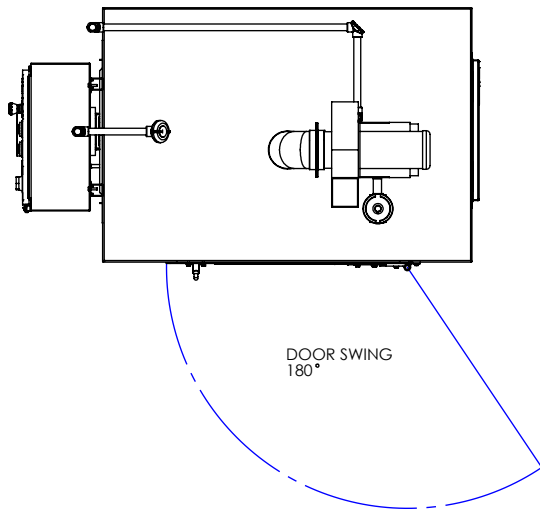

PLAN VIEW

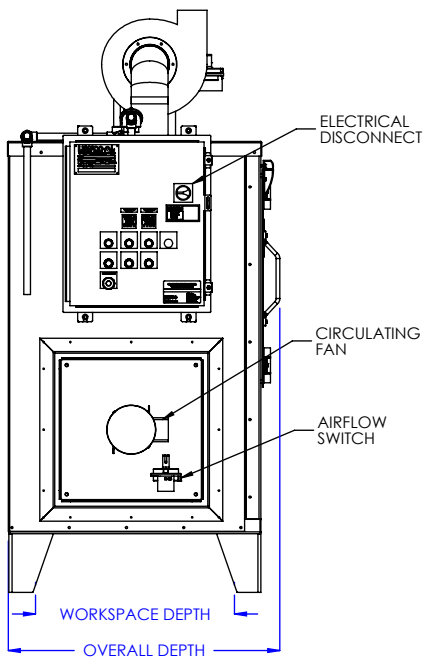

LEFT SIDE ELEVATION

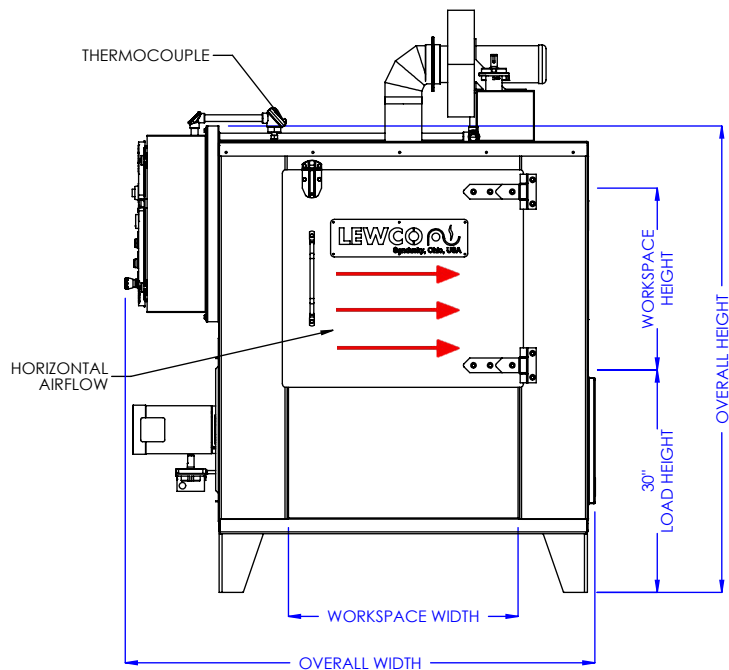

FRONT ELEVATION

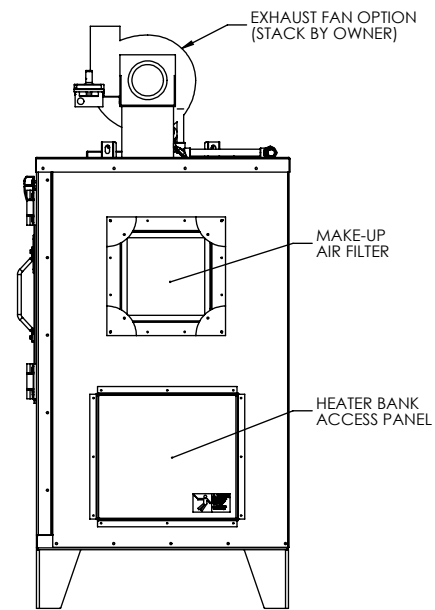

RIGHT SIDE ELEVATION

MODEL: SCB05EH, NFPA Class B

DESCRIPTION: NORMAL DUTY CABINET OVEN,
500° F, ELECTRIC, HORIZONTAL AIRFLOW

WARNING: OVENS PROCESSING FLAMMABLE VOLATILES OR COMBUSTIBLE MATERIALS REQUIRE SPECIAL NON-STANDARD SAFETY FEATURES TO COMPLY WITH NFPA 86, "CLASS A" OVENS. KNOW THE PROPERTIES OF THE MATERIALS BEING HEATED. EXPLOSION OR FIRE MAY RESULT FROM MISAPPLICATION.

LEWCO, INC. IS COMMITTED TO CONTINUOUS IMPROVEMENT AND RESERVES THE RIGHT TO CHANGE DESIGNS AND SPECIFICATIONS WITHOUT NOTICE.

THIS DRAWING MUST NOT BE COPIED, REPRODUCED OR USED FOR ANY PURPOSE WITHOUT THE WRITTEN CONSENT OF LEWCO, INC. ALL RIGHTS RESERVED.

DATE: 10/10/2017

REV. 001

PAGE: 1 of 2



706 LANE ST. SANDUSKY, OH 44870, U.S.A.

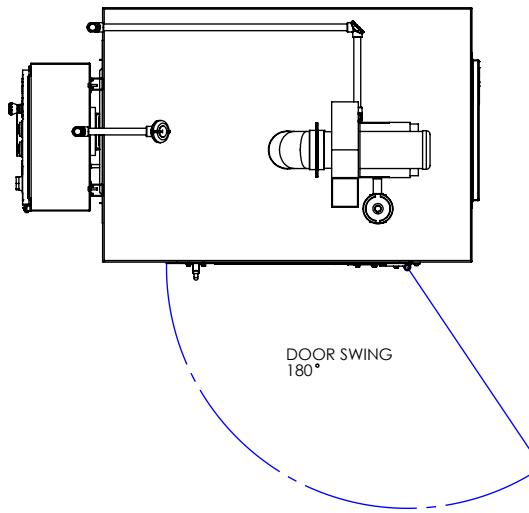

PLAN VIEW

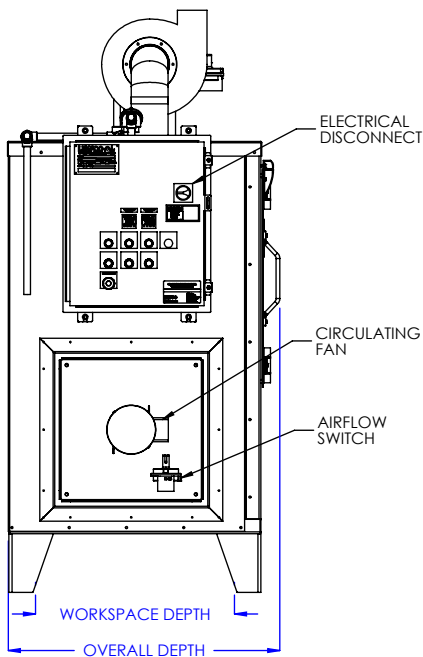

LEFT SIDE ELEVATION

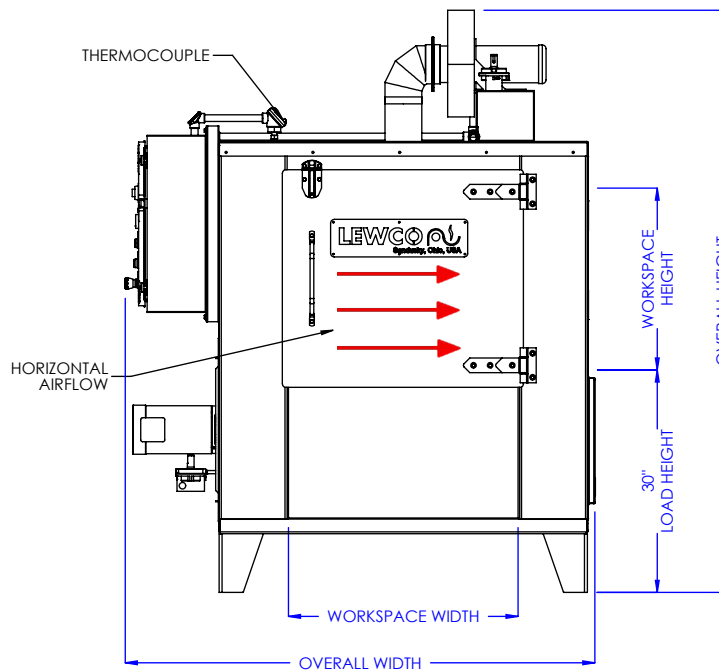

FRONT ELEVATION

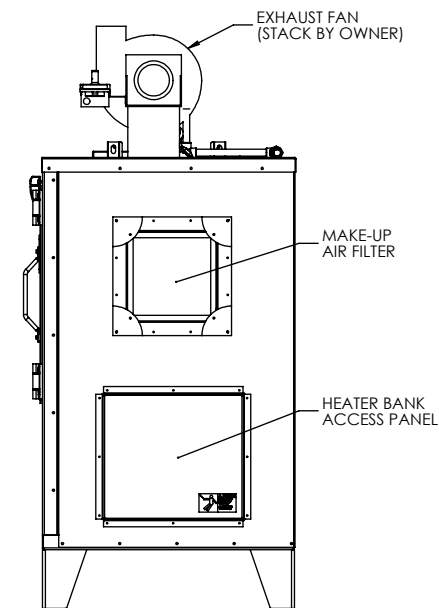

RIGHT SIDE ELEVATION

MODEL: SCB05EH, NFPA Class A

DESCRIPTION: NORMAL DUTY CABINET OVEN,
500° F, ELECTRIC, HORIZONTAL AIRFLOW

WARNING: OVENS PROCESSING FLAMMABLE VOLATILES OR COMBUSTIBLE MATERIALS REQUIRE SPECIAL NON-STANDARD SAFETY FEATURES TO COMPLY WITH NFPA 86, "CLASS A" OVENS. KNOW THE PROPERTIES OF THE MATERIALS BEING HEATED. EXPLOSION OR FIRE MAY RESULT FROM MISAPPLICATION.

LEWCO, INC. IS COMMITTED TO CONTINUOUS IMPROVEMENT AND RESERVES THE RIGHT TO CHANGE DESIGNS AND SPECIFICATIONS WITHOUT NOTICE.

THIS DRAWING MUST NOT BE COPIED, REPRODUCED OR USED FOR ANY PURPOSE WITHOUT THE WRITTEN CONSENT OF LEWCO, INC. ALL RIGHTS RESERVED.

DATE: 10/10/2017

REV. 001

PAGE: 2 of 2



706 LANE ST. SANDUSKY, OH 44870, U.S.A.